



→ THE FIRST EUROPEAN ASTEROID 'FLYBY'

Rosetta operations for the flyby of asteroid 2867 Steins

Sylvain Lodiot, Andrea Accomazzo, Mathias Lauer, Trevor Morley & Paolo Ferri
Directorate of Operations and Infrastructure,
ESOC, Darmstadt, Germany

Gerhard Schwehm
Directorate of Science and Robotic Exploration, ESAC,
Villanueva de la Cañada, Spain

The first flyby of an asteroid by a European spacecraft was a major success, both from the scientific and engineering points of view. This was the first planned scientific objective of ESA's Rosetta mission, and the optical navigation campaign, performed for the first time in Europe, gave results well beyond expectations.

The experience gained during this encounter will be a key driver and an asset for the navigation towards the second asteroid flyby (Lutetia) in 2010, as well as during the comet approach when Rosetta makes its rendezvous with Comet

67P/Churyumov-Gerasimenko in 2014. Similar flyby strategy and planning concepts will be reused for the Lutetia flyby.

Rosetta's story

Rosetta was the first planetary 'cornerstone' mission of ESA's Scientific Programme, launched on 2 March 2004 on a ten-year journey to a rendezvous with Churyumov-Gerasimenko. Since then, it has travelled more than four thousand million kilometres around our Solar System, more than halfway to its target.

Rosetta's cruise phase began after launch with the injection into an escape trajectory by an Ariane 5. Rosetta then performed three planetary swingbys that allowed the

spacecraft to be accelerated and its trajectory steered according to the flight plan. The first Earth swingby, conducted one year after launch, marked the first of this kind of operations for the team at ESOC and its success boosted confidence for the more-challenging operations to come.

There were two more successful swingbys in 2007, at Mars in February and at Earth in November. The swingby at Mars was one of the most challenging operations of the mission so far, with its closest approach at 250 km and the spacecraft flying for 24 minutes in the shadow of the planet, a condition it had not been designed for. The spacecraft survived this critical and fundamental mission phase without any problem.

Because Rosetta crosses the main asteroid belt twice during its long cruise, the mission was also given secondary scientific objectives: the flybys of asteroids Steins and Lutetia (2010). The spacecraft is now on its fourth orbit around the Sun and crossed the asteroid belt for the first time in September 2008. On 5 September, Rosetta passed asteroid 2867 Steins at a distance of about 800 km and at relative velocity of 8.6 km/s.

The challenges

The flyby strategy for asteroid Steins that was proposed and validated before launch could not satisfy several of the requirements thought necessary by the scientists to achieve all the scientific objectives. These were: 'good' asteroid illumination conditions, observation at phase angle zero (the angle between the spacecraft and the Sun as seen from the asteroid), fly by at closest possible distance, no interruption of observation around closest approach, 'good' pointing performance and 'good' synchronisation of payload operations with flight events.

These requirements would mean pushing the spacecraft to its performance limits, especially in terms of attitude dynamics (reaction wheels torques, rotational speed of appendages). They would mean violating thermal constraints (exposing the spacecraft 'cold' sides to the Sun) and decreasing the navigational accuracy (navigation errors having an impact on the pointing attitude). They would introduce demanding constraints from an operations planning point of view, such as the need for late orbit determination, late correction manoeuvres and last-minute command updates. A new strategy was therefore identified and agreed after launch.

Exposing spacecraft cold sides

During the asteroid approach, the spacecraft attitude would be such that the Sun shines on its 'warm' side, which was allowed within mission rules. However continuing the observation of the asteroid during and after closest approach would mean exposing the cold sides of the spacecraft to the Sun for the remaining observation time. This was 'forbidden' because it would expose thermally sensitive parts of the spacecraft to the Sun.

The initial scenario was therefore changed and an 'attitude flip manoeuvre' (180-degree rotation around +Z axis) was

Projection to ecliptic plane

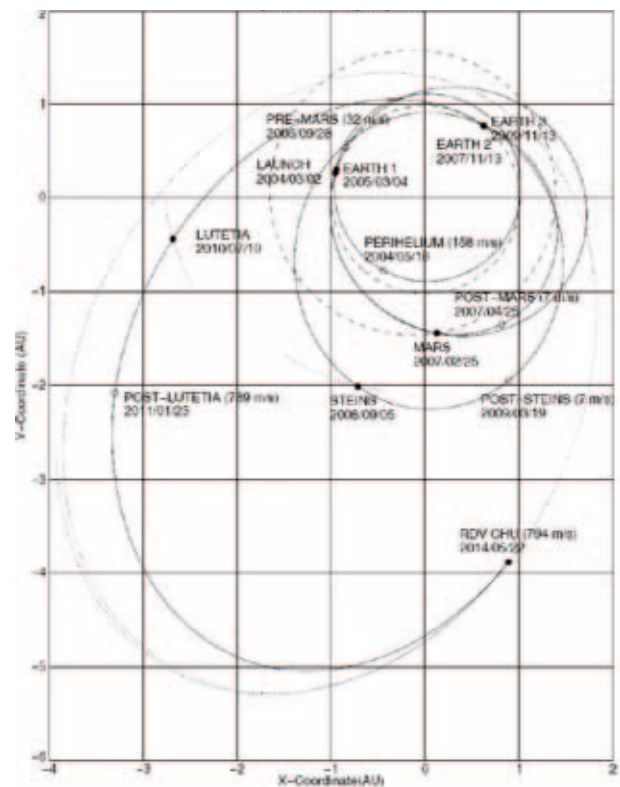

Rosetta's interplanetary trajectory

introduced between 40 and 20 minutes before closest approach. This would expose the thermally sensitive parts to the Sun but only for a limited acceptable time. The spacecraft could then continue pointing the scientific instruments towards the asteroid following a thermally benign attitude profile.

Shortly after the flip, the spacecraft would be commanded to start tracking the asteroid autonomously. This is the Asteroid Flyby Mode where the attitude is adjusted automatically such that the instruments always point towards the asteroid.

Defining the flyby parameters

The spacecraft and the asteroid move on elliptic orbits around the Sun. For several days around closest encounter however, the relative motion was almost linear due to the small curvature of the trajectories. The spacecraft was approaching and flying by the asteroid along an almost straight line with a relative speed of 8.6 km/s (31 000 km/h). These flyby conditions (direction, speed and time of flyby) were defined by the overall geometry of the interplanetary orbits of Steins and Rosetta, and could not be changed.

→ Why fly by asteroids?

The history of our Solar System, its formation and evolution, can be studied by investigating the various Solar System bodies. Asteroids are important because they pre-date the planets and retain a record of that phase of the Solar System's formation: they are the pieces that got left behind in the process of planet formation.

It is believed that, in the early Solar System, dust accretion in the pre-solar nebula formed the 'planetesimals', very early stages of planets consisting of loose groupings of rocks and other matter. These bodies later collided and coalesced, while others

impacted each other with such energy that they fragmented. After millions of years, the coalescence won and several planets were formed.

In the asteroid belt, however, the accretion process was halted with the formation of Jupiter because its enormous gravity shepherded the asteroids into more orderly orbits. This reduced the chances of collision and effectively stopped the asteroids from developing any further into planets.

Asteroids are therefore like a piece of Solar System DNA: they keep a 'memory' of the Solar System

formation. Collisions have led to a huge number of asteroids with different compositions and internal structures: all with their own history. It is therefore important to visit and study as many different types of asteroids as possible to understand their evolution.

The flyby of 2867 Steins was the first European asteroid encounter and only the eighth in spaceflight history. Steins is a rare, iron-poor, E-type irregular-shape asteroid with an estimated diameter of 4.6 km and, as such is of much interest to the scientific community.



Only two conditions were adjustable. The first one was the flyby distance (closest approach distance between the spacecraft and the asteroid). For observation purposes, especially for the science cameras on board Rosetta, and to fulfil the scientific requirements, the flyby distance had to be as small as possible. Therefore a distance of 800 km was selected, driven by the maximum rotation speed that the spacecraft could sustain to keep the instruments pointed to the asteroid during the flyby.

The other adjustable characteristic of the flyby was its orientation with respect to the asteroid. To fulfil the requirements, the best choice was to fly by on the dayside of

the asteroid. With this orientation, the phase angle dropped to zero degree at some instance during the approach. At that time, the asteroid appeared fully illuminated by the Sun when observed by a camera on the spacecraft.

Validation of the new scenario

An in-flight validation test with the spacecraft was required, in order to prove the robustness and safety of the new scenario. To be as representative as possible, this test had to take place when the angular position of Rosetta relative to Earth and the Sun was the same as the one during the actual Steins flyby. The 24 March 2008 was the only day satisfying these conditions.

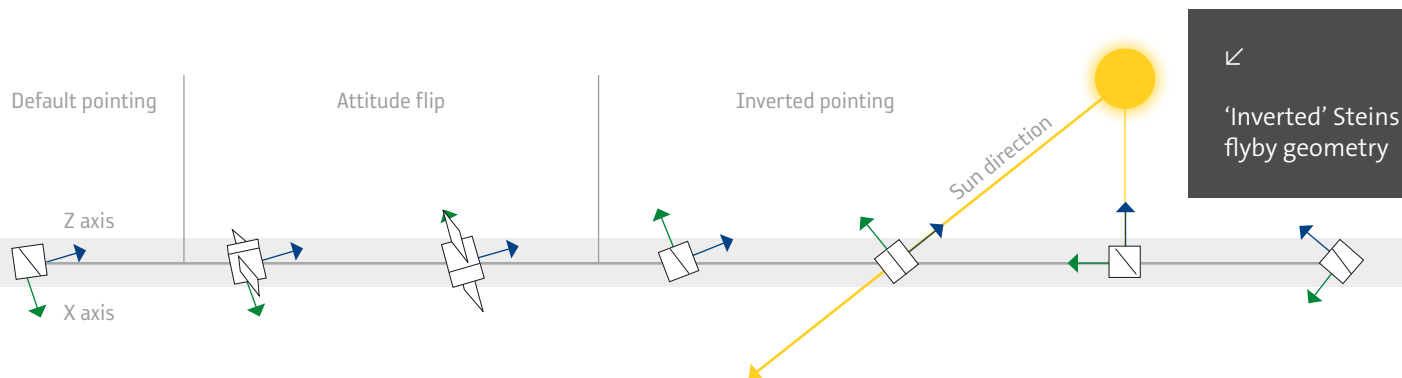

To gain confidence in this validation test, simulations were first performed at the manufacturer premises with the test bed used to validate the Attitude and Orbit Control System (AOCS) during the design phase. The scenario was also run several times with the ESOC software simulator emulating the AOCS software. Both tests were successful and gave the final 'go' for the in flight test.

The simulated closest approach time was at 12:00 on 24 March, with the flip manoeuvre taking place between 11:20 and 11:40 and Rosetta entering the spacecraft autonomous tracking mode just after the end of the flip. Some parameters had to be 'faked' to allow this special spacecraft mode to work in absence of a real asteroid to track, but from a performance, thermal and dynamic point of view, the test was fully representative.

The timeline of activities was also exactly the same as planned for the real Steins flyby. The whole test took place outside ground station coverage. There was great relief when the New Norcia ground station acquired an X-band signal from Rosetta on 25 March 2008, the first contact with the spacecraft after the test completion! This meant that the spacecraft had gone through all the phases of the test and this was the first indication that everything had worked out nominally.

Rosetta then entered Near Sun Hibernation Mode for several months until early July 2008. This quiet period in spacecraft activities allowed all teams to focus on the Steins flyby phase, perform further validation tests and complete the flyby operations timeline. The ESOC simulator was tested and configured to be able to track a simulated Steins asteroid and enter the autonomous tracking mode. It was also used to rehearse the real flyby timeline, including failure cases to make sure that the real scenario was robust enough.

A few days after Near Sun Hibernation Mode exit, an active payload checkout took place in July 2008. It included payload calibrations, onboard software maintenance and interference testing activities to confirm payload readiness for the Steins flyby. After four weeks of heavy workload on all teams involved, including the Rosetta Science Operations Centre (RSOC) in Spain, all payload teams confirmed their 'go' for the flyby activities.

→

Steins seen from the first observation slot on 4 August (Steins marked, with a magnitude of about 12 at that time, i.e. fainter than the detection limit of the navigation camera). The bright star at upper left is Iota Virginis of the constellation Virgo with magnitude 4. This is the brightest object in the field of view. The extended white spots are stars. Almost all other small white spots are artefacts from the CCD sensor (pixel dark current).

Three simulations in August 2008 made sure all operations teams were properly trained and ready for the critical flyby operations and that, as far as possible, all procedures were in place to react to any spacecraft contingency situation. Rosetta was ready for the start of the flyby phase.

Approach and flyby

The spacecraft orbit is routinely determined throughout the mission using radiometric data (range and Doppler measurements). Similarly, the asteroid had been observed from telescopes around the world over several decades. These observations were used to determine its orbit around the Sun. Based on these independent estimates, it was possible to predict the positions of the spacecraft and the asteroid at the time of closest approach only within a limited accuracy in the order of some 100 km.

The spacecraft had to be guided towards the planned flyby conditions with much better accuracy than that. This was achieved with the combination of traditional radiometric measurements and the use of images of the asteroid taken with the onboard navigation cameras and the OSIRIS science camera.

So the first step of the navigation campaign was to determine the current orbits of the asteroid and the spacecraft more accurately. All three cameras were used to acquire images showing the asteroid together with the surrounding star field. By analysing such images, the direction of Steins relative to the star background could be determined with an accuracy of less than 0.1 millidegree.

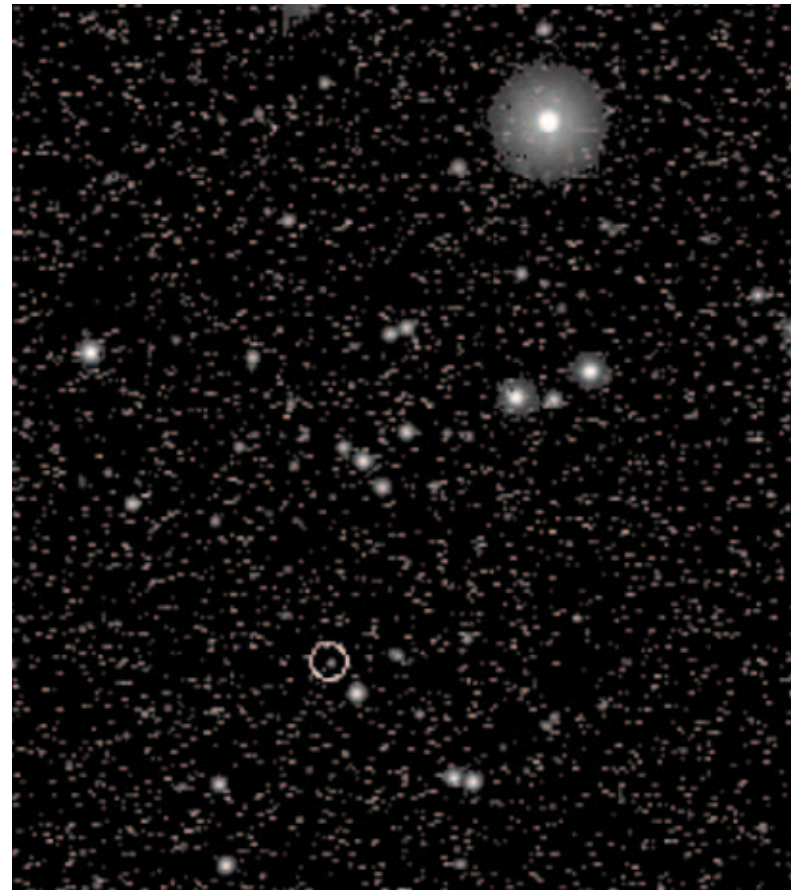

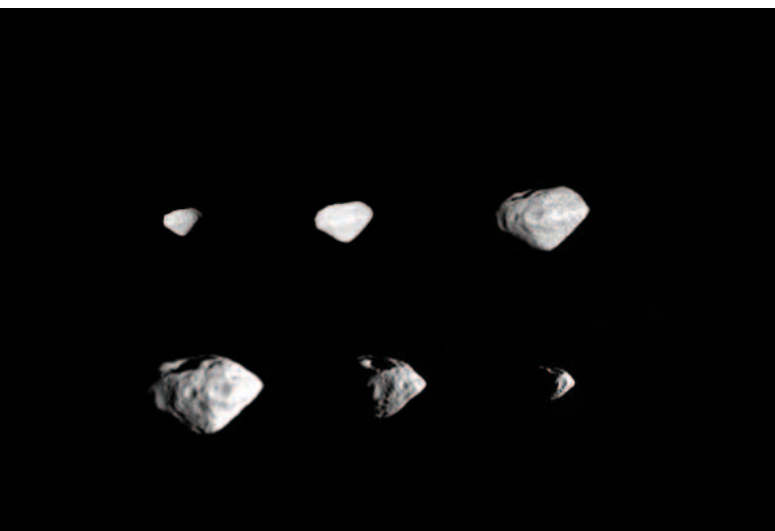

Narrow angle (left) and wide angle (far left) camera composites of Steins

These measurements allowed estimating the relative direction of the target with increasing accuracy (the angular error of 0.1 millidegree is equivalent to a smaller position error when the distance to the target becomes shorter). It was the first time this technique was applied to navigate a European spacecraft.

The subsequent steps of the navigation campaign were carried out only if an orbit correction turned out to be necessary. They consisted in determining an optimal trajectory correction manoeuvre to adjust the orbit in order to meet the flyby conditions.

Planning process

The planning process was one of the most complicated in the mission so far. It had to be defined in an incremental way, accommodating the flyby navigation strategy and link of some commanding products to the results of previous planning activities.

The four weeks before the flyby included 13 optical navigation slots, two trajectory correction manoeuvre slots and the first payload activities. The flyby week was by far the most complicated from a planning point of view, with the final four navigation slots and final three manoeuvre slots. The high accuracy achieved in the navigation and the excellent performance of the spacecraft meant the ground team only needed two of the planned manoeuvre slots, for small corrections of the spacecraft trajectory.

The final critical 'go'/'no go' decision for entering the spacecraft autonomous tracking mode was to be taken between seven and two hours before closest approach, because the navigation cameras would not be able to track the asteroid before. All activities had also to take into account the 20 minutes signal travel time between Earth and the spacecraft, which did not allow for any immediate reaction from ground to any unexpected event or malfunction.

Payload activities and expected scientific output

All but three Rosetta payload instruments were operated during the Steins flyby. They covered: imaging and

spectroscopy, magnetic and radiation environment monitoring of Steins, search for gas and dust particles around the asteroid, as well as radio science.

The scientists expected to be able to derive the accurate size, shape, volume, rotation rate and albedo of the asteroid. They would be able to perform multi-colour imaging of its surface and multi-wavelength spectral mapping, determine its surface morphology, composition and density, analyse its environment in a search for satellites and detect potential gas release, as well as study the interaction of the asteroid with the space environment.



Closest approach was 802.6 km, occurring only four seconds later than the time estimated for planning purposes.



First scientific results

Steins was measured at 5.9 x 4.0 km. The first preliminary results showed that the asteroid is dominated by a large crater on the northern part as well as an interesting chain of craters. The impact that created the large crater was most probably so immense it could have almost broken apart the asteroid. With craters of different ages and a 'regolith' cover inferred from degraded craters, Steins must have experienced a complex collisional history. The Rosetta instrument teams are currently analysing the huge amount

of science data generated and the results will be published in the coming months.

Navigation camera tracking

Twelve hours before the flyby, the navigation camera was commanded to track the asteroid for the first time. In this mode, the camera should autonomously detect the asteroid and determine periodically its position in the field of view. These measurements are used by the attitude control system of the spacecraft in its autonomous tracking mode during the flyby. According to the mission rules, successful camera tracking was a condition that had to be fulfilled for the 'go' for entering autonomous tracking mode.

In case of 'no go', the spacecraft would follow a back-up attitude profile predetermined on the ground, based on the best knowledge of the flyby trajectory. Due to the high speed of the flyby, and the high uncertainty in the time, which could not be reduced by optical measurements, it was likely that the instruments would not point accurately enough at Steins if this back-up profile was followed.

When the first telemetry arrived from the camera in tracking mode, it became clear that the unit was not performing as

the asteroid just in time for the 'go'/'no go' decision for autonomous tracking mode.

Thanks to the successful near real-time operational support, it was possible to achieve the objectives set for the conditions of the scientific observations. It turned out only after full attitude and orbit reconstruction that the optimum pointing performance had not been fully met throughout the tracking period. Data analysis is ongoing to support the preparation of the Lutetia asteroid flyby in July 2010, to achieve the best possible performance.

Navigation results

One day before the flyby, based on all the optical navigation data, including 340 measurements of the direction of Steins seen from Rosetta, it was expected that the closest approach distance would be 800.4 km and occur at 18:38:15 UTC on 5 September. The uncertainty on the flyby time was twelve seconds, equivalent to 105 km along the relative trajectory, and so quite high.

After the flyby, the processing of OSIRIS camera images contributed to provide very precise, final navigation results. The distance to Steins at closest approach was 802.6 km



A scene of celebration in the Rosetta mission control room at ESOC after the flyby

expected. After careful check-out of telemetry, including images that were commanded to support the analysis, it was concluded that the malfunction was due to a special combination of effects which comprised the presence of 'warm' pixels on the CCD (pixels that generated a significant signal without optical stimulation), the software algorithm of the camera for processing the CCD output and the apparent size of the target, which was still smaller than the size of a single pixel. It was also concluded, that these conditions would not improve sufficiently in time for the 'go'/'no go' decision.

Several other camera settings with the redundant camera unit were discussed and tested: modification of the optical filter, disabling of automatic exposure control and modification of the tracking window size. With only two hours to go to the flyby, a setting was found in which both cameras (nominal and redundant) could successfully track

and occurred at 18:38:20.1 UTC, only five seconds later than the final prediction and four seconds later than the targeted time estimated in mid August for payload planning purposes. Rosetta flew slightly south of the Steins-to-Sun direction such that the minimum phase angle was just 0.27 degrees and occurred 117 seconds before closest approach.

Without the benefit of optical navigation, the desired closest approach distance would have been missed by more than 100 km.

Rosetta now continues its long journey towards the comet. The spacecraft has never before been so far away from Earth and the Sun. A last swing-by at Earth in November 2009 will boost the spacecraft on its final target orbit to approach the comet in 2014. ■