



National Aeronautics and
Space Administration
Jet Propulsion Laboratory
California Institute of Technology

Educational Products	
Educators	Grades 6-12

EV-2001-05-003-JPL

Catch the Wind: The QuikSCAT Story

An Adventure in Math, Science and Technology

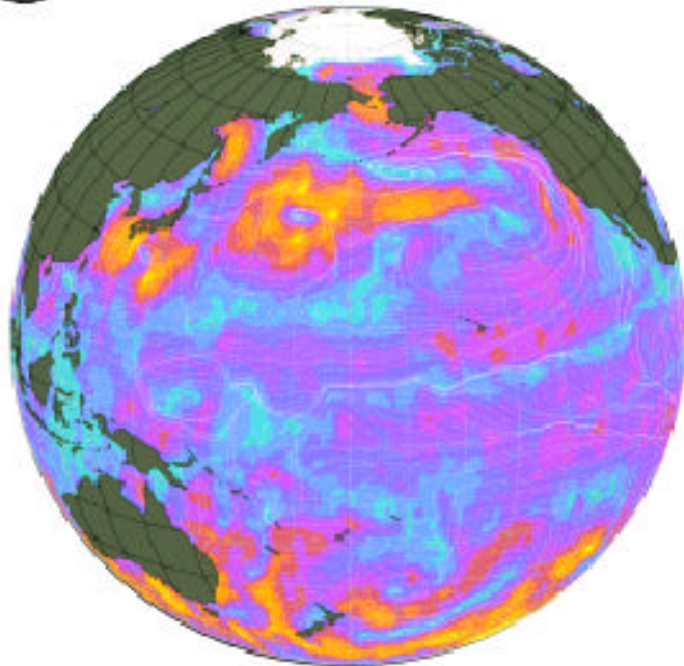

Video Resource guide for educators...

Catch The Wind

The QuikSCAT Story

Video Resource Guide for Educators

This resource guide is a companion to the video: *Catch the Wind: The QuikSCAT Story*. Though the activities in this guide can stand alone, we recommend that the teacher first show the video in the classroom, in order to establish the context of these activities and projects, and to motivate student interest in them.

The *Catch the Wind* video is suitable for students age 11 to adult, and the activities in this guide are designed to be used in mathematics and science classes grades 6 through 12. The table of contents indicates which activities are suitable for which specific math and science topics.

Through their help in creating this resource, the scientists and engineers of the QuikSCAT mission have extended the significance of that mission beyond the valuable data collected by the SeaWinds instrument, into the nation's classrooms. It is their hope that the *Catch the Wind* video helps teachers to inspire and educate a generation of new scientists and engineers, upon whose abilities and interests the future of Man's space exploration efforts will depend.

This resource guide was produced for the National Aeronautics and Space Administration (NASA) by the Foundation for Advancements in Science and Education (FASE), and is sponsored by the Jet Propulsion Laboratory, a division of the California Institute of Technology.

Copyright © 2001 California Institute of Technology



Table of Contents

	Page
The QuikSCAT Mission	4
Standards	6
Backscatter demonstration	8
Build and test a model which demonstrates how radar is reflected from waves on the surface of the ocean.	
Satellite Speed	11
Compute the speed of the satellite by choosing the relevant data among several given facts.	
Color and Heat Transfer	16
Investigate the relationship of an object's color to its heat transfer properties.	
Solar Panel Orientation	20
Do a mathematical experiment to determine just how important it is that the solar panels which produce QuikSCAT's power are facing in the right direction.	
Signal Timing	30
Use the Pythagorean theorem to find the distance that the radar signal must travel as it goes from the QuikSCAT satellite to the surface of the Earth and back, and compute the amount of time taken.	
The First QuikSCAT Orbit	34
Learn about the properties of an ellipse and sketch the elliptical path of QuikSCAT in its first orbit around the Earth.	
QuikSCAT and the Law of Gravity	39
Use fundamental equations of physics to determine QuikSCAT's speed in orbit.	
Power Requirements	42
Determine the size that the solar panels on QuikSCAT's spacecraft must be to supply the electrical power needed by the craft and the instrument.	

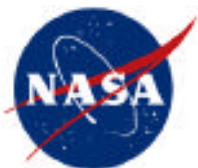

Antenna Angle 45
Use trigonometry to calculate how the angle of the QuikSCAT antenna affects the size of the region over which ocean winds can be measured.

An Alternative QuikSCAT Power Source 47
Use an understanding of exponential functions to evaluate the feasibility of a possible alternative power source for QuikSCAT.

Glossary 50



The QuikSCAT Mission

QuikSCAT is a "quick recovery" mission to fill the gap created by the loss of data from the NASA Scatterometer (NSCAT), when the satellite it was flying on lost power in June 1997. QuikSCAT launched from California's Vandenberg Air Force Base aboard a Titan II vehicle at 7:15 p.m. Pacific Daylight Time on June 19, 1999. It collects important ocean wind data begun by NSCAT in September 1996. The SeaWinds instrument on the QuikSCAT satellite is a specialized microwave radar that measures near-surface wind speed and direction under most weather and cloud conditions over Earth's oceans.

SeaWinds uses a rotating dish antenna with two spot beams that sweep in a circular pattern. The antenna radiates microwave pulses across broad regions of the Earth's surface. The instrument concentrates on collecting data over the ocean but also collects useful data over snow, ice and land in a continuous, 1,800-kilometer-wide band, making approximately 400,000 measurements and covering more than 90% of Earth's surface in one day.

QuikSCAT's Science Objectives

- Acquire all-weather, high-quality, high-resolution measurements of near-surface wind speed and direction over global oceans.
- Better understand the interaction of the ocean and the atmosphere.
- Combine wind data with measurements from scientific instruments in other disciplines to help us better understand the mechanisms of global climate change and weather patterns.
- Study both annual and semi-annual rain forest vegetation changes.
- Study daily/seasonal sea ice edge movement and Arctic/Antarctic ice pack changes.

QuikSCAT's Operational Objectives

1. Improve weather forecasts by using wind data in numerical weather- and wave-prediction models.
2. Improve storm warning and monitoring.

The SeaWinds/QuikSCAT project is managed for NASA's Earth Science Enterprise by the Jet Propulsion Laboratory, a division of the California Institute of Technology.



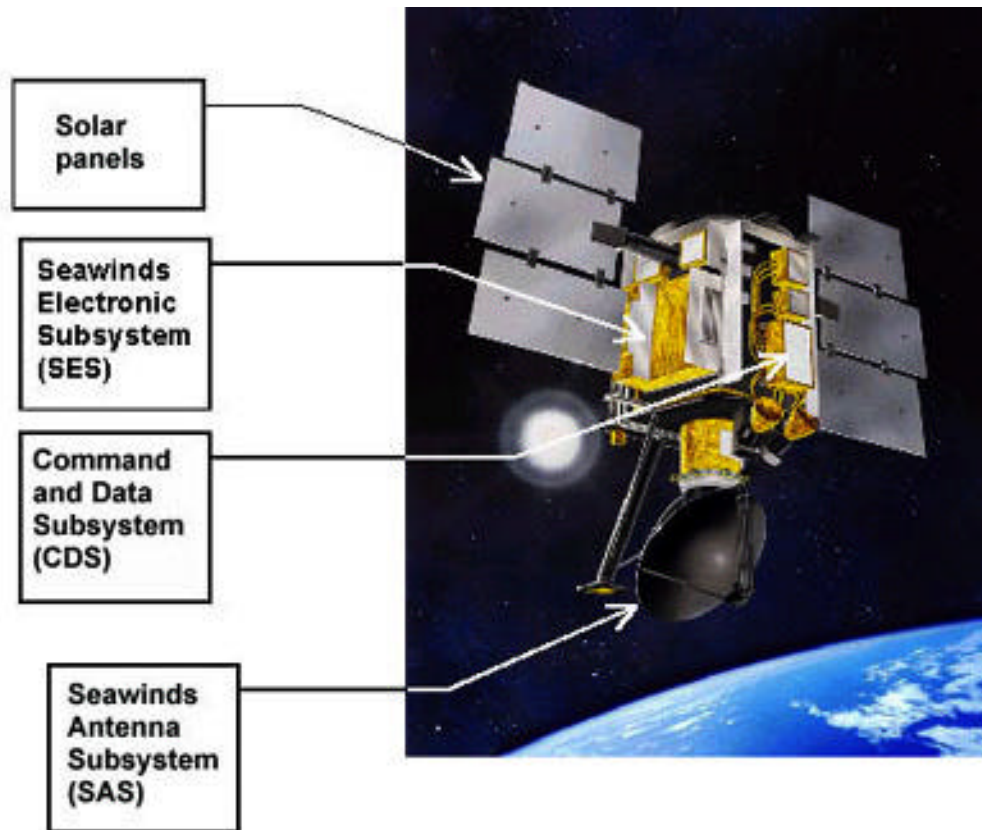

SeaWinds Scatterometer Subsystems

The SeaWinds instrument is made up of three main components, known as subsystems. These are the Electronic Subsystem (SES); Antenna Subsystem (SAS); and Command and Data subsystem (CDS).

The electronic subsystem creates the radar signal that is sent to the antenna, which then beams it down to the Earth's surface. The antenna also receives the return signal, or backscatter. The signal is then routed back to the SES through waveguides, which are rectangular metal pipes that allow RF energy to travel from one point to another.

The command and data subsystem contains the computer that controls the scatterometer instrument. It supplies engineering telemetry (e.g. temperatures and operating voltages and currents) and science data (backscatter measurements) to the spacecraft, which then transmits the data to ground stations. The CDS also receives commands from the spacecraft.

Everything in the scatterometer instrument except the actual rotating antenna dish is redundant, meaning there are duplicate parts in case one fails.

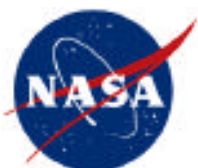

More information about the QuikSCAT and other NASA/JPL Scatterometer missions can be found at: <http://winds.jpl.nasa.gov>

Standards

Activity or Project	Subject	Grade Levels	Topic(s)	Knowledge and Skills
Backscatter demonstration	Science	6-12	Physics: Electromagnetic Spectrum	<ul style="list-style-type: none"> Understands the phenomenon of scattering
Satellite Speed	Mathematics	6-9	Geometry: Circles	<ul style="list-style-type: none"> Understands and can apply the formulas "circumference = pi*diameter" and "circumference = 2*pi*radius"
Color and Heat Transfer	Science	6-12	The Nature of Science: Scientific Inquiry Physics: Energy, Power and Heat	<ul style="list-style-type: none"> Can carry out an investigation to test a prediction or hypothesis through the collection and analysis of data Can graphically analyze the relationship between variables in an investigation Understands that heat can be transferred by conduction, convection and radiation and can give examples of each.
Solar Panel Orientation	Mathematics	6-9	Algebra: Patterns, Relations and Functions	<ul style="list-style-type: none"> Understands the concept "function". Has informal familiarity with the behavior of the cosine function.
	Science	6-12	Applied Science and Technology: Electric Power Generation	<ul style="list-style-type: none"> Understands various methods of solar energy collection.
Signal Timing	Mathematics	6-9	Geometry: Lines, Polygons and Angles	<ul style="list-style-type: none"> Understands the Pythagorean Theorem and can apply it to solving problems related to right triangles.
	Science	6-12	Physics: Electricity and Magnetism, Electromagnetic Spectrum	<ul style="list-style-type: none"> Knows that electromagnetic radiation travels in a vacuum at 186,000 miles per second
The First QuikSCAT Orbit	Mathematics	6-9	Geometry: Ellipses	<ul style="list-style-type: none"> Understands the characteristics of an ellipse
	Science	6-9	Physics: Mass, Motion and Force	<ul style="list-style-type: none"> Knows that satellites orbit their primaries on elliptical paths.
QuikSCAT and the Law of Gravity	Mathematics	6-9	Algebra: Equations	<ul style="list-style-type: none"> Can do basic operations on both sides of an equation in such a way as to preserve the equality
	Science	6-12	Physics (mass, motion, and force)	<ul style="list-style-type: none"> Knows that the strength of the gravitational force between two masses is proportional to the masses and inversely proportional to the square of the distance between them



Power Requirements	Mathematics	6-9	Algebra: Equations	<ul style="list-style-type: none"> • Can do basic operations on both sides of an equation in such a way as to preserve the equality.
	Science	6-12	Physics: Energy and Power; Applied Science and Technology: Electric Power Generation	<ul style="list-style-type: none"> • Understands the concept “power” • Can apply the equation “energy = power x time” • Understands various methods of solar energy collection
Antenna Angle	Mathematics	8-12	Trigonometry	<ul style="list-style-type: none"> • Can use sine, cosine and tangent ratios to solve for unknown sides of angles in right triangles
An Alternative QuikSCAT Power Source	Mathematics	10-12	Algebra: Exponential Functions	<ul style="list-style-type: none"> • Can determine the equation of an exponential function that closely matches a set of points



Teaching Guidelines for "Backscatter Demonstration"

Subject: Science

Topics: Physics: Electromagnetic Spectrum

Grades: 6 - 12

Knowledge and Skills:

- Understands the phenomenon of scattering

Materials (for each team of students)

- Flashlight
- Three pieces of aluminum foil, approx 8" x 12"

Procedure:

This activity is best done with students working in teams of two or three.

After students have completed the experiment and the analysis, discuss the results as a class.

Optionally, you may choose to have different teams use larger or smaller folds in the foil, to see how this affects the results.

Note: If you are teaching a high school physics class, you may wish to point out that the backscattering of radar from the surface of the ocean differs from the situation above in one important respect: the wavelength of the radar used is approximately the same size as the wavelets which cause it to backscatter. In fact, the wavelength of radar selected for the Seawinds instrument is intentionally chosen to match the size of the wavelets, as this gives a particularly strong backscatter effect.

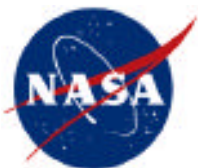

Backscatter Demonstration

Engineering requirement

Develop a way to measure winds over the ocean's surface from a satellite-based instrument.

Scientific principles

When light (or any other form of electromagnetic radiation) is reflected from a smooth surface, it bounces off in a symmetrical way.

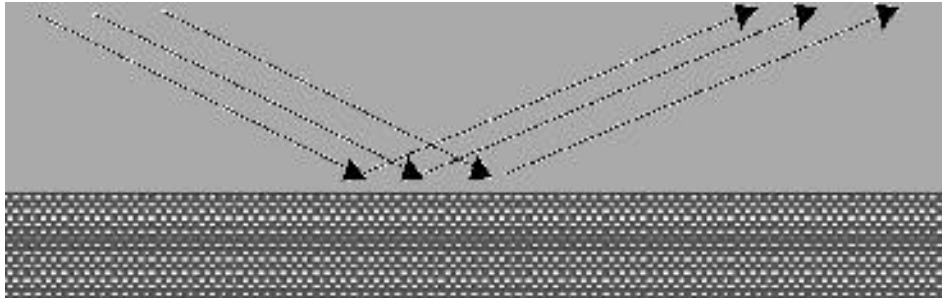

Observation

When wind blows over the surface of the ocean, it makes that surface rough.

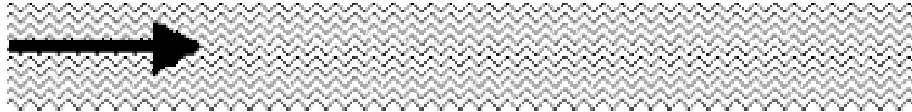

Hypothesis

When a surface is not smooth, the radiation will be reflected in many directions. Some of the radiation might even come directly backwards towards its source.

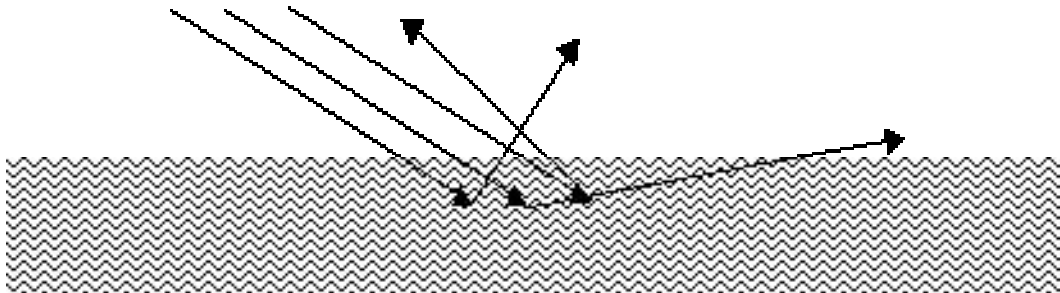

Experiment

Lay out a sheet of aluminum foil (approximately 8" by 12") on a table. Darken the room, and put your eyes at the level of the table, and look across the foil. Hold a flashlight next to your head and shine it across the foil.

Turn on the lights. Take a second sheet of foil the same size as the first, and crumple it up, then flatten it out again. Put this sheet next to the first sheet, and repeat the procedure with the flashlight, looking first at one piece of foil and then the other. What do you observe?

Turn on the lights. Take a third sheet of foil, the same size, and fold it in half, then in half again, and so on until the strip is _ to _ inch wide. Unfold this sheet and lay it next to the other two. Repeat the procedure with the flashlight, turning the folded sheet of foil in various directions (through always flat on the table) as you look at it. What do you observe?

Experiment analysis

1. Explain your observations in relation to the hypothesis above. Does it seem to be true?
2. Explain how your observations relate to how the SeaWinds instrument detects the direction of the wind.

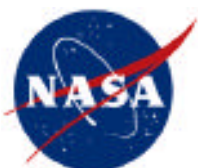

Teaching Guidelines for "Satellite Speed"

Subject: Mathematics

Topics: Geometry: Circles

Grades: 6 - 9

Knowledge and Skills:

- Understands and can apply the formulas "circumference = π *diameter" and "circumference = $2*\pi$ *radius"

Materials: (none)

Procedure:

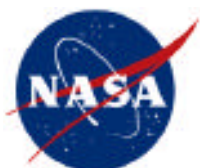

Satellite Speed Satellite Orbits

SOME BASIC FACTS ABOUT SATELLITES IN EARTH ORBIT

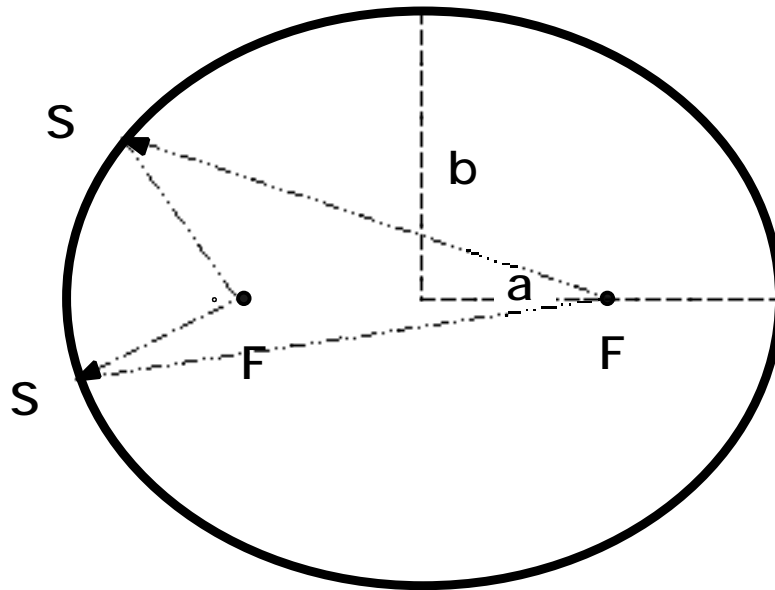

The Ellipse

The geometric path that all satellites follow is that of an ellipse

The above figure is an ellipse. Each of the “F” points are called a focus of the ellipse. Some of the interesting features of this geometric form are that the two distances from the “F” points to the point “S”, as we move along the elliptic path, always add up to the same value. In the case above, it is obvious that the distance “b” is less than the distance “a”. When we talk about orbits about some body in space, such as the Earth, that body will always be at one of the “F” points.

Now imagine that we bring the “F” points closer and closer together, making the distances “b” and “a” more equal. Eventually, the two “F” points will be on top of each other and we have “a”=“b”. We then have a “circle”, a special form of the ellipse. For the most part, we try to make satellites that go around the Earth to have circular orbits, so that they are always about the same distance from the center of the Earth (and therefore from the surface also).



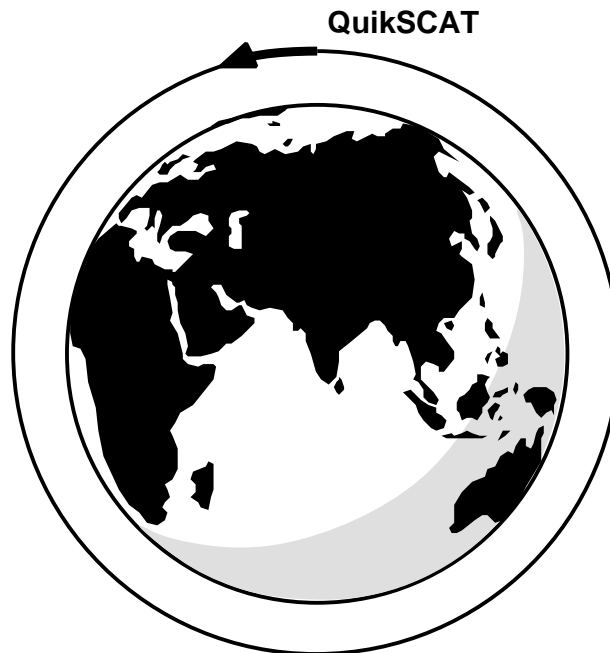

We have put the QuikSCAT satellite into a circular orbit. Is there a relatively easy way we can determine the speed at which a satellite moves in its orbit? The answer is yes, if we know its distance from the center of the Earth (or visa a versa).

In our design of the QuikSSCAT mission, we determined the best operating altitude, based on several factors such as the strength of our radar signal, etc. Then the distance we want is simply this altitude, plus the radius of the earth.

We must now thank one of the early scientists of what we might call the modern age, Johannes Kepler , During the period of about 1601 to 1619, Kepler completely changed our understanding of orbits in space. One of the things he proved was that all orbits are ellipses, as we said at the start. He also found surprising simple, but very powerful mathematical tool.

We call the time it takes to make one complete orbit the “period” of the orbit. We will use the symbol “P” for this value. Let us also call the altitude (The average distance above the surface of the Earth) of our satellite “h” and the radius of the Earth “R”. The distance from the center of the Earth to the satellite will then simply be “R + h”. One more bit of math, let us call this value of “R + h” by the symbol of “D”. Now here is what Kepler discovered.

P^2 is proportional to D^3 ,

Or in the form of an equation,



$$P^2 = \text{Constant } D^3 .$$

With some work, we could figure out this constant, but if we set this equation up as a ratio, we do not need to know the constant. In addition, as long as we are consistent with our units, we can use any ones we like and the ratio equation does not change. That is

$$\frac{P^2_1}{P^2_2} = \frac{D^3_1}{D^3_2}$$

What good does this ratio equation do us? Well if we know the information about any one orbit about a particular body, we can figure out the information about any other orbit. Where can we get the information we need about an orbit---by looking at the following table of special “imaginary” orbits. That is, we will imagine in our mind that our body in space is a perfect sphere, is completely smooth, and has no atmosphere. We can even “hold our breaths for a moment” and imagine this also about the Earth. Now what would be the period for a satellite to go around our body once, when it is just “skimming the surface”—that is, the total distance from the center of the body to our satellite is just the radius of the body, **R**.

For the Earth this period is 84.7 minutes. We will assume the radius of the Earth is 6378 kilometers or 3964 miles.

To show how easy it will now be to determine the period and average altitude of a satellite about one of the bodies in our table, let us look at an Earth Satellite at an average altitude of 150 miles or in metric units about 240 km and ask the question, “What is its Period?”. In place of the subscripts of “1” and “2” in equation (1), let us use “R”, for surface, in place of “1” for reference orbit and “S”, for satellite, in place of “2”.

After you do the normal cross multiplying and solve for P^2_S , you get,

$$P^2_S = (P^2_R D^3_S) / D^3_R$$

Using the reference orbit for Earth and the numbers of our problem, we get,

$$P^2_S = (84.7^2 \times 4114^3) / (3964^3).$$



Note that the 4114 value comes from adding the radius of the Earth, 3964 miles, and the altitude of the spacecraft, 150 miles.

We can use a hand calculator (or paper and pencil) to multiply our the numbers to get

$$P_s^2 = (7174 \times 6.9629E10)/(6.2288E10)$$

Where we use the symbol of “E” to indicate a power of “10”, and working our way through the equation we get:

$$P_s^2 = 4.9952E14/6.2288E10 = 8019$$
$$P_s = 89.5 \text{ minutes}$$

It might surprise you that the period is only a little under five minutes longer that our reference orbit at the surface of the Earth.

NOW HERE IS YOUR PROBLEM

The altitude of QuikSCAT is 803 kilometers. How long will it take to go around the Earth one time—That is, what is it “period”.

Can you now use the information you have to estimate the speed that QuikSCAT moves along in its orbit path? (HINT: remember the relationship of “distance = rate X time”)



Teaching Guidelines for "Color and Heat Transfer"

Subject: Science

Topics: The Nature of Science: Scientific Inquiry; Physics: Energy, Power and Heat

Grades: 6 - 12

Knowledge and Skills:

- Can carry out an investigation to test a prediction or hypothesis through the collection and analysis of data
- Can graphically analyze the relationship between variables in an investigation
- Understands that heat can be transferred by conduction, convection and radiation and can give examples of each.

Materials (for each team of students):

- A thermometer
- A shallow dish
- Paper towels
- Food coloring

Procedure

This project provides an opportunity to teach students how to design an experiment in such a way that the results are reproducible.

Before beginning, ask students to think about what they would have to do in their experiment to make sure that another scientist would be able to duplicate their results. Then have each team of experimenters write down the aspects of the experiment that would have to be controlled.

Discuss the answers and compile a list of all such factors: the amount of water, the temperature of the water at the beginning of each trial, the wattage of the light bulb, the distance between the light source and the dish of water, the room temperature, the size and type of the dish used.

Discuss the fact that all of these factors must be the same for each different color tested in order for the results to be valid.

To speed up the lab part of this experiment, you may wish to have each team test a different color (with all other factors identical for all teams).



Optionally, you can ask students to plot a temperature vs. time graph showing the rise in temperature of the thermometer after the light is turned on. The temperature should be read every 30 seconds, until it is no longer changing.



Color and Heat Transfer

Engineering requirement

A satellite instrument such as QuikSCAT must have a relatively constant temperature while it orbits around the Earth, in spite of the fact that it is sometimes in direct sun and sometimes in shadow.

Scientific principles

Normally, heat can be transferred into or out of an object in one of three ways:

Conduction: If you place another body of a different temperature in direct contact with the first body, heat energy will transfer between them so that eventually they reach the same temperature.

Convection: If a relatively hot body is in contact with a gas or liquid (such as the atmosphere, or under water), the molecules of the gas that are next to the body will gain heat energy, speed up their motion and spread farther apart, moving up and away from the body and carrying the heat energy with them.

Radiation: A body emits electromagnetic radiation (radio waves, microwaves, infrared, light waves, ultraviolet, X-rays, etc), depending on its temperature. This is why a light bulb glows when electricity passes through and heats up its filament. A body can also absorb such radiation and become hotter (which is why a microwave oven works).

In the vacuum of space, there is almost nothing* to conduct heat, and there is no air or liquid to carry heat away by convection. There is only radiation.

Problem

What can be done to reduce the amount of radiation that a body absorbs or emits?

Observation

Things that are black or dark in color seem to heat up faster when placed in the sun.

*A satellite in space will be impacted by very tiny particles such as micrometeorites, and by even smaller particles (ions, protons, neutrons, electrons), and these impacts will transfer heat into the satellite. However, the amount of heat energy that the satellite might absorb in this way is quite small.



Hypothesis

The color of an object affects how much radiation it absorbs.

Experiment

Put a thermometer on top of a paper towel in a shallow dish, and cover it with a small amount of water. Use food coloring to dye the water different colors, and observe for each color how quickly the temperature of the water changes when struck by the bright light from an incandescent desk lamp. (Note: You will need to make sure that the thermometer and water start out at the same temperature each time before turning on the light.)

Experiment analysis

In what ways does your experiment represent what would actually happen to a satellite in space? In what ways is it different? Could those differences mean that your results would not be valid for a satellite?

Next step

After you turn off the light bulb, what happens to the temperature? Is that different for different colors?

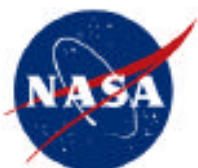

Teaching Guidelines for "Solar Panel Orientation"

Subject: Mathematics

Topics: Algebra: Patterns, Relations and Functions

Grades: 6 - 9

Knowledge and Skills:

- Understands the concept "function"
- Has informal familiarity with the behavior of the cosine function

Subject: Science

Topics: Applied Science and Technology: Electric Power Generation

Grades: 6 - 12

Knowledge and Skills:

- Understands various methods of solar energy collection

Materials: none

Procedure

This activity offers an informal opportunity for students to investigate the behavior of the sine function while in the middle grades, simply by counting "rays".

It is not necessary, or even advisable, to try to name the function being investigated. However, once students have made their tables, and graphs, you may want to get them to notice some of the key characteristics of the function with questions such as these:

At what angle does the panel absorb the most rays? The least?

When the angle of the panel is halfway up, at 45° , does it absorb half as much sunlight as at 90° ? At what angle does the panel absorb half as much sunlight?



Is there much difference in absorption if the panel is at 80° or 90°?

Is there much difference in absorption if the panel is at 40° or 50°?

Is there much difference in absorption if the panel is at 10° or 20°?

What do you think would happen if the angle becomes more than 90°? Try it.

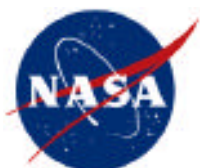

Solar Panel Orientation

Study the two following diagrams. In each, solar radiation enters from the right and strikes a solar panel, which is seen in an edge-on view from the side.

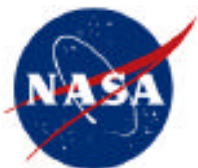
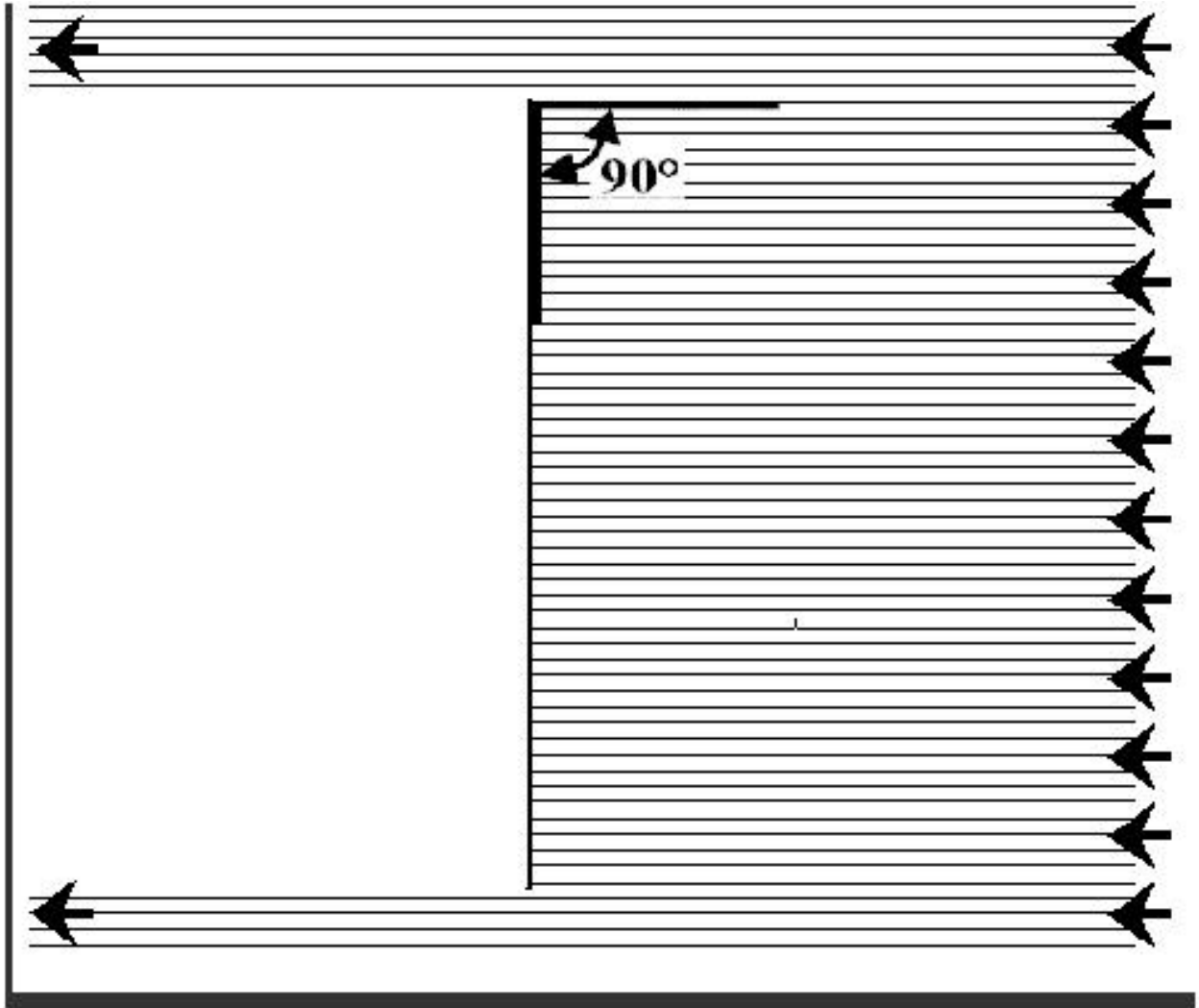

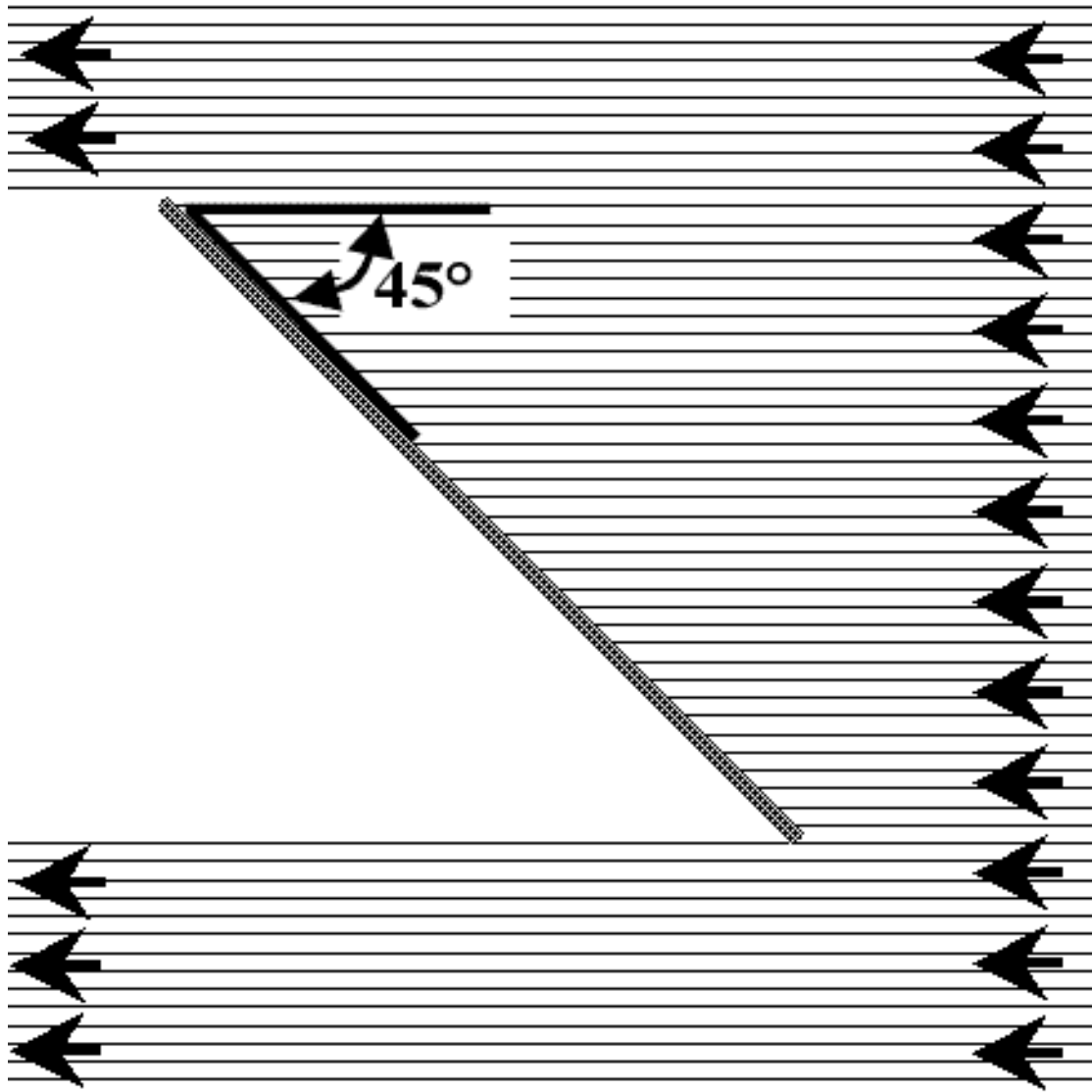

In the first diagram, the incoming radiation arrives at an angle of 90° to the face of the solar panel. In the second diagram, the angle is 45° .

You can see that more of the radiation is absorbed by the panel in the first diagram than in the second. One way to compare these is to count the "rays" of sunlight that strike the panel in each case.

When the sunlight strikes the panel at an angle of 90° , the panel absorbs 50 rays. How many rays does the panel absorb when sunlight strikes at 45° ? Put this number into the correct location in the chart on the next page.



Write a fraction that compares the number of rays absorbed at an angle of 45° to the number that is absorbed at an angle of 90° . Change this fraction to a percent. Put that percent into the correct location in the chart below.

Measure the length of the solar panels in the drawings on the previous pages. Using the pictures of "rays" on the following pages, draw solar panels with the same length at various angles to the incoming rays. Count how many rays your solar panels will intercept. Use your data to fill in this chart:

Angle	# of rays absorbed	Percent of maximum
90°	50	100%
80°		
70°		
60°		
50°		
45°		
40°		
30°		
20°		
10°		
0°		

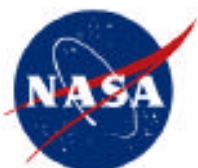

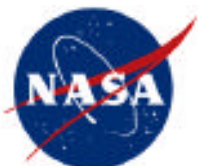
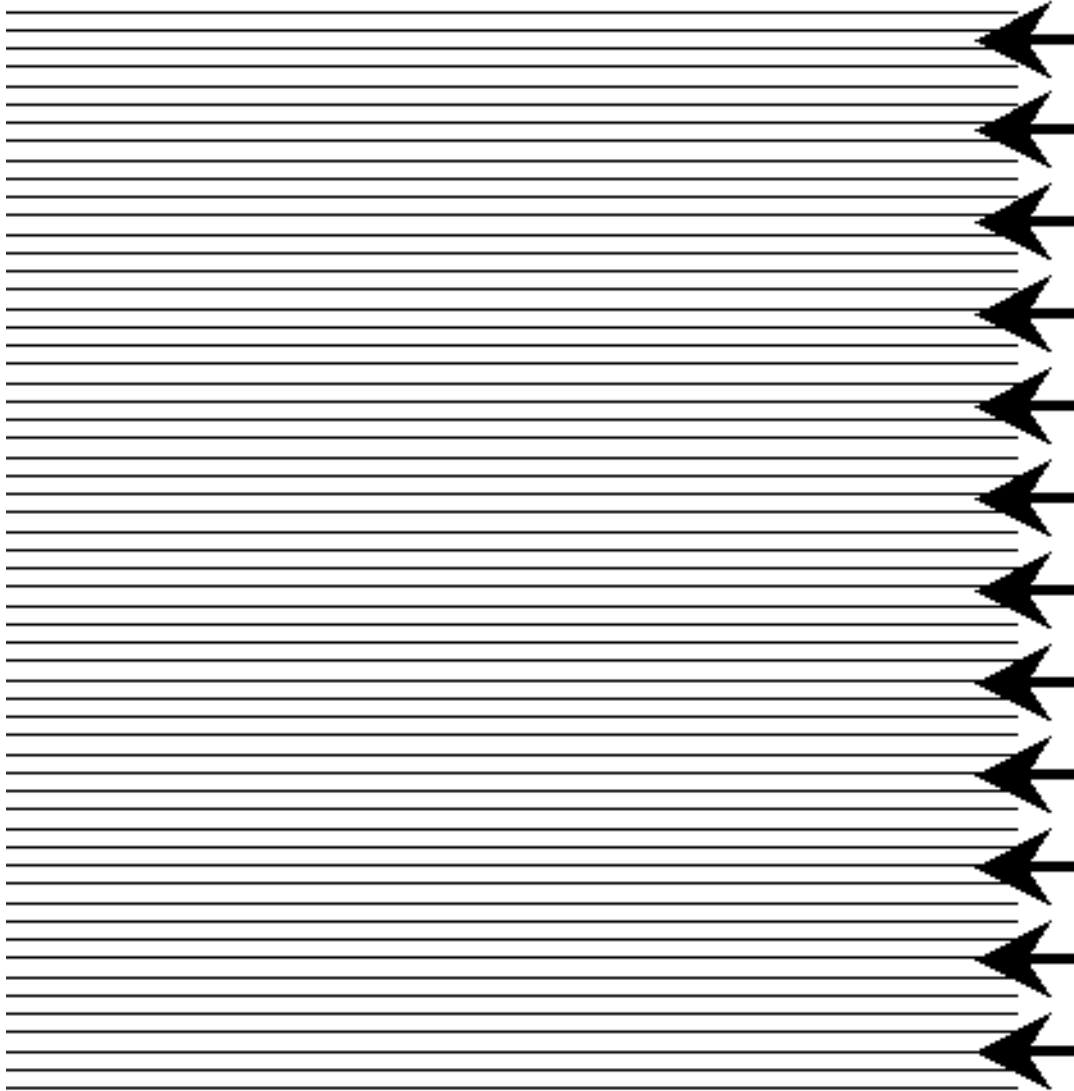

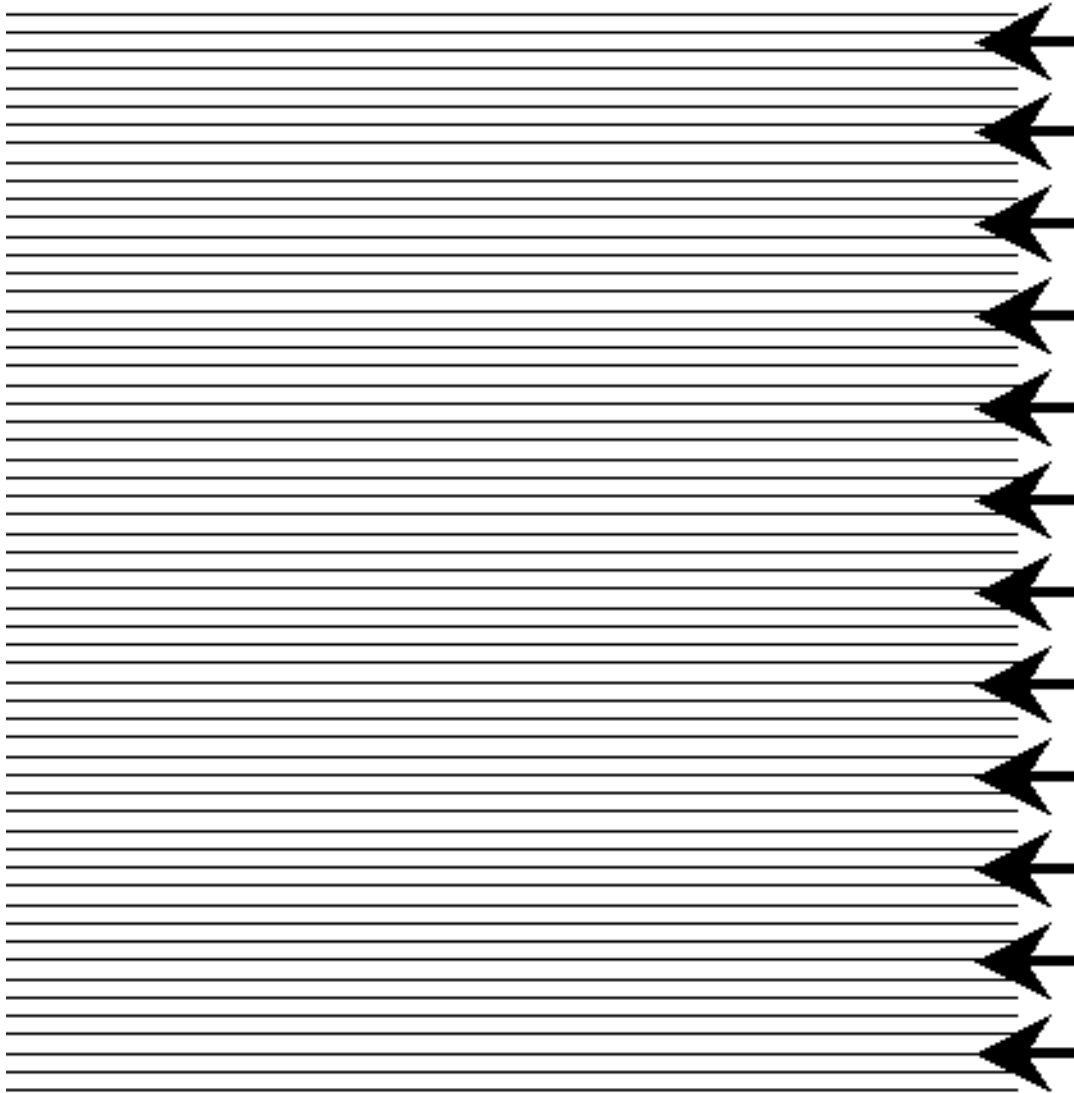

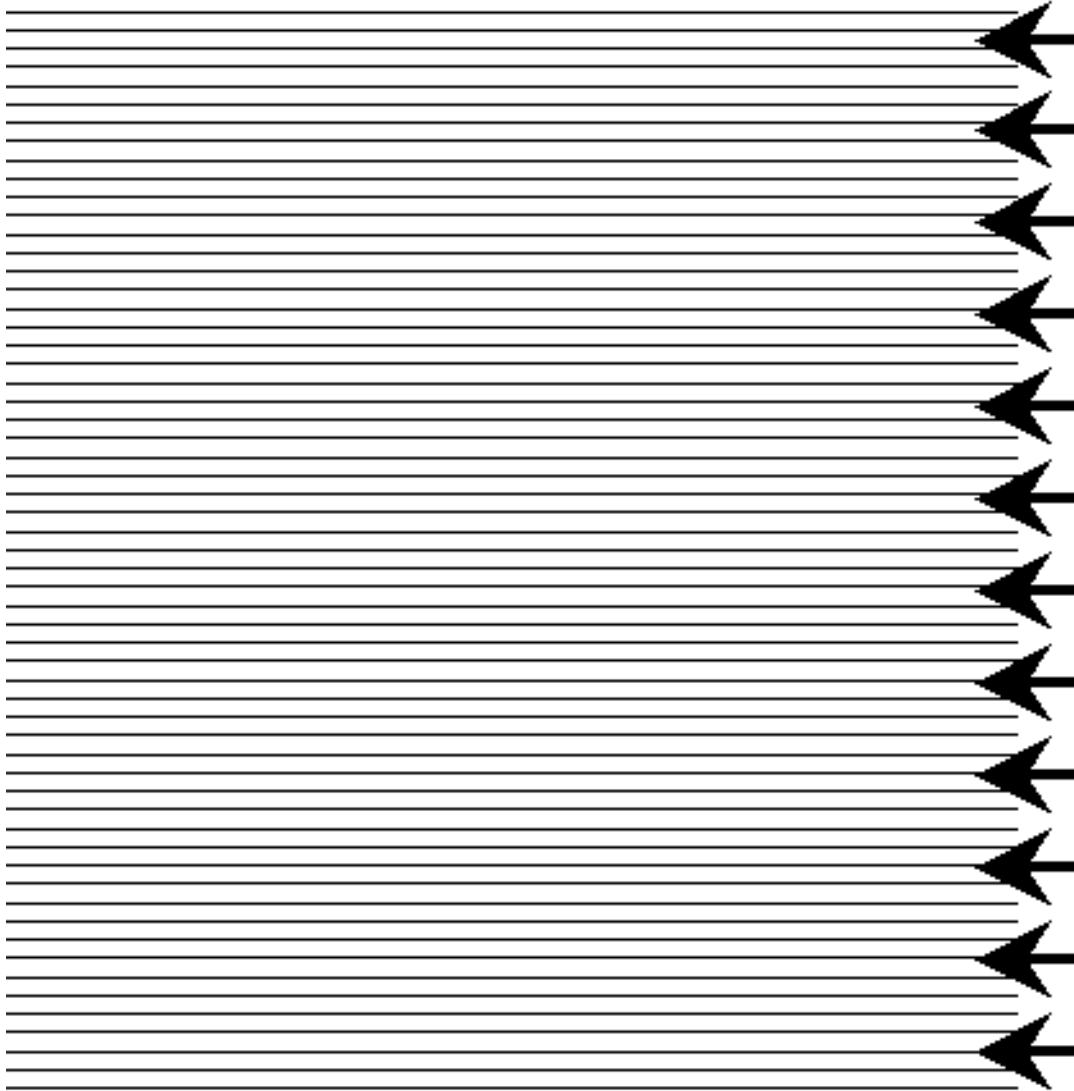

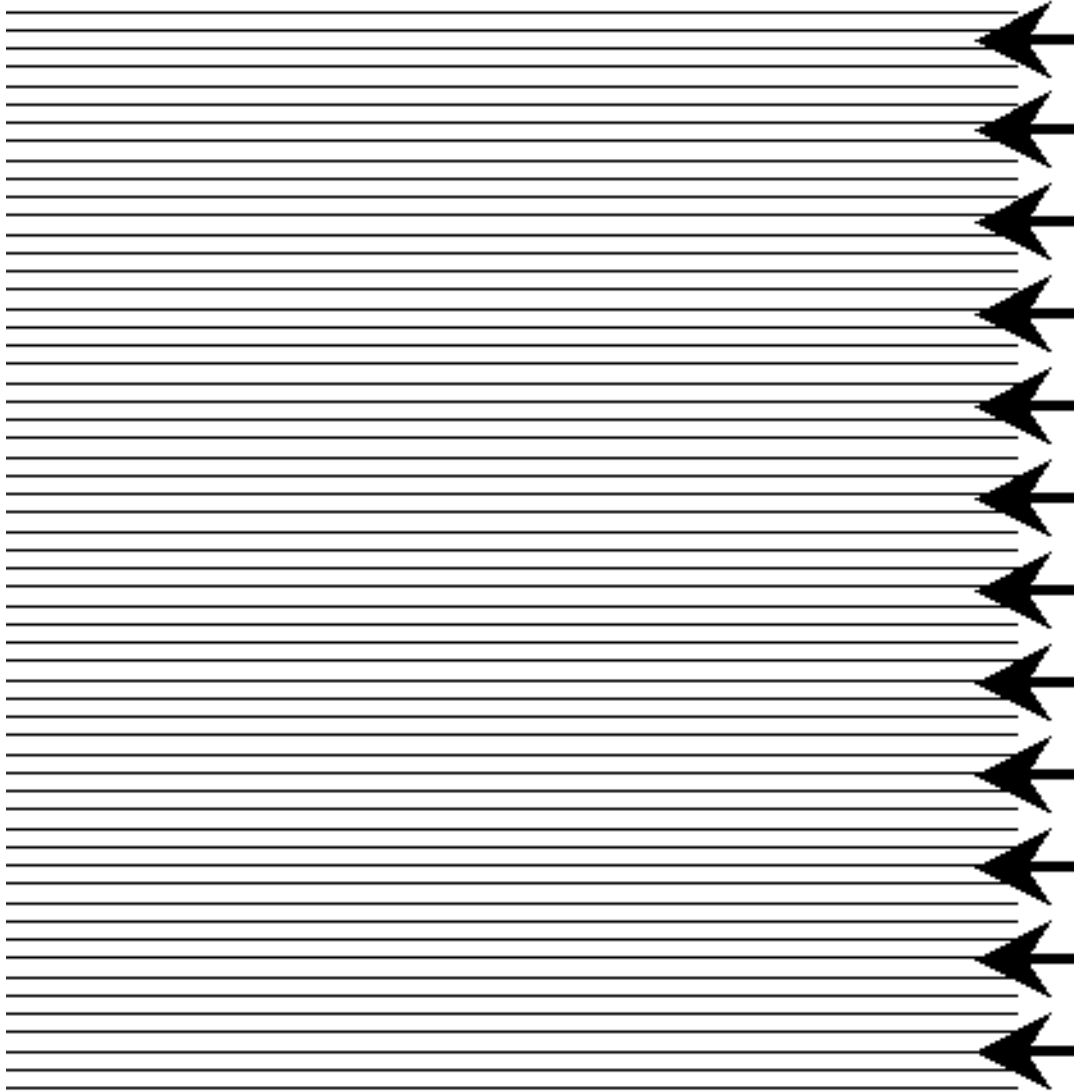

Now make a graph that shows the results of your chart. Use the graph below as a model:

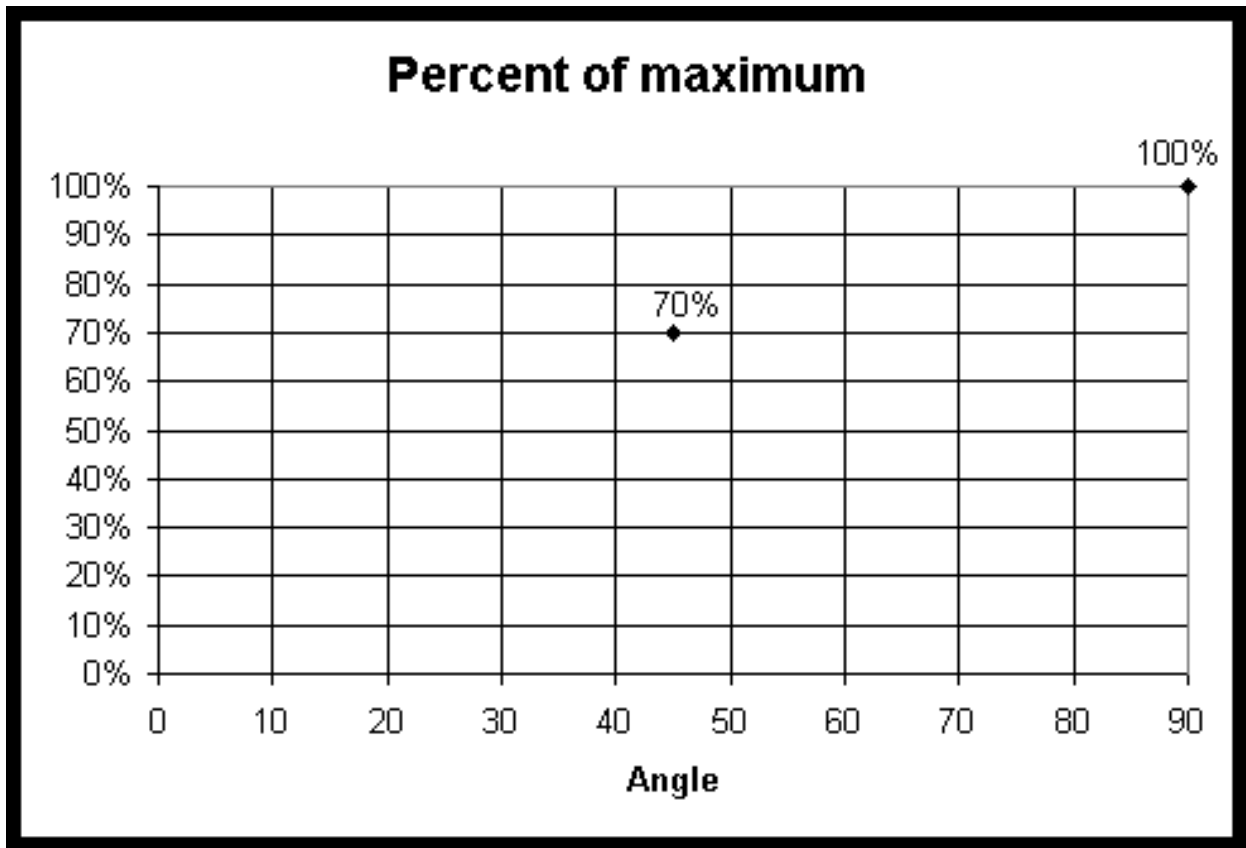

Use your data to answer these questions:

1. The spacecraft is designed to keep the solar panels always directly facing the sun, so that the radiation arrives at an angle of 90° . What percent of incoming sunlight would be lost if the orientation of the spacecraft changed a little bit, so that the incoming angle was 85° ?
2. Suppose that someone at a ground station observed that the amount of power being produced by the panels had dropped to 60% of its normal maximum, even though the spacecraft was still in the middle of the sunlit side of the Earth in its orbit. If this drop were being produced by the fact that the spacecraft had somehow turned so that the solar panels were no longer directly facing the sun, exactly how far (how many degrees) would the solar panels have had to turn?
3. How many degrees would the solar panels have to be tilted away from the sun for the power to drop to 50% of its maximum value?



Teaching Guidelines for "Signal Timing"

Subject: Mathematics

Topics: Geometry: Lines, Polygons and Angles

Grades: 6 - 9

Knowledge and Skills:

- Understands the Pythagorean Theorem and can apply it to solving problems related to right triangles

Subject: Science

Topics: Physics: Electricity and Magnetism, Electromagnetic Spectrum

Grades: 6 - 12

Knowledge and Skills:

- Knows that electromagnetic radiation travels in a vacuum at 186,000 miles per second

Materials: none

Procedure

Solving this problem involves the use of the Pythagorean Theorem to find the distance from QuikSCAT to the point where the radar signal strikes the surface of the ocean, then the use of the rate formula to determine the time taken.

For the first signal discussed, the distance (length of the hypotenuse) is found by

$$\begin{aligned} \text{distance} &= \text{square root of } (8002 + 9002) \\ &= 1204 \text{ kilometers (km)} \end{aligned}$$

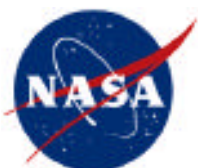

The time is, therefore,

$$\begin{aligned}\text{time} &= \text{distance/speed} \\ &= 1204 \text{ km}/(300,000 \text{ km per second}) \\ &= .004 \text{ seconds}\end{aligned}$$

For the second signal, the distance is 1140 km, and the time is .0038 seconds.



Signal Timing

In order to set the timing of radar pulses, we need to know exactly how much time it will take a radar signal to travel from the QuikSCAT instrument to the ocean and back to QuikSCAT.

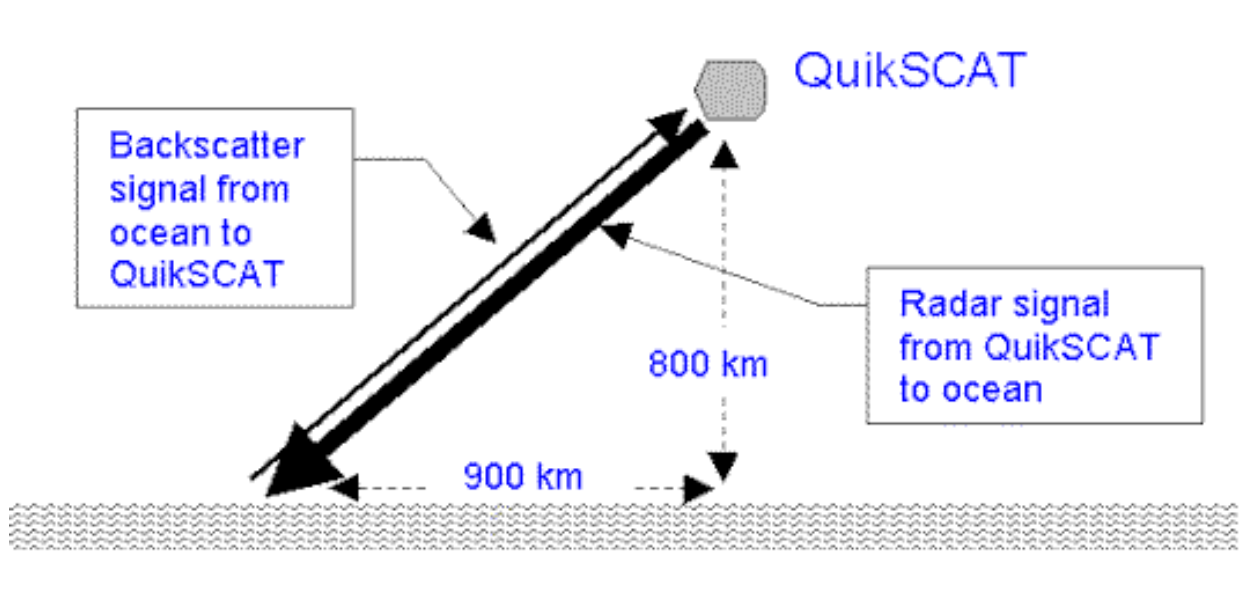

The diagram above shows the QuikSCAT satellite in position over the ocean. Use it to answer these questions:

1. *What distance does the radar signal travel on its path from the satellite to the ocean's surface?*
2. *Radar travels through the atmosphere at almost exactly the speed of light. How long will it take the signal to travel from the QuikSCAT satellite to the oceans' surface? Back to the satellite?*
3. *What is the duration of time from the instant that the signal is sent out by the satellite until the instant that its backscatter signal is received?*



QuikSCAT will be emitting two radar signals, at slightly different angles. The angle of the first signal is shown on the previous diagram. This diagram shows the second radar signal:

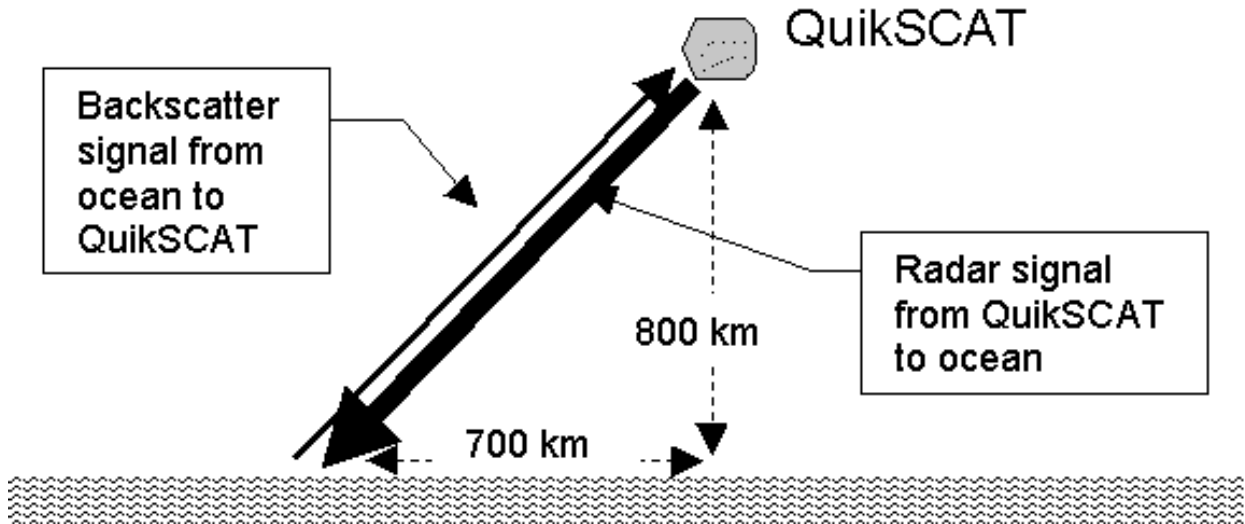

4. For this second signal, what is the duration of time from the instant that the signal is sent out by the satellite until the instant that its backscatter signal is received?



Teaching Guidelines for "The First QuikSCAT Orbit"

Subject: Mathematics

Topics: Geometry: Ellipses

Grades: 6 - 9

Knowledge and Skills:

- Understands the characteristics of an ellipse

Subject: Science

Topics: Physics (mass, motion, and force)

Grades: 6 - 9

Knowledge and Skills:

- Knows that satellites orbit their primaries on elliptical paths.

Materials: none

Procedure

You may wish to tell students that whenever one body orbits another under the influence of gravity, the orbit is always in the shape of an ellipse, with the body being orbited located at one of the ellipse's foci. This is predicted by Kepler's third law and is a result of Newton's law of gravity (as well as Einstein's theory of General Relativity, which replaced Newton's law).

Strictly speaking, this applies only in the case where there are no other bodies present which are also exerting gravitational influence on the two bodies. In reality, when the path of a satellite orbiting around the earth must be exactly determined, the influence of the moon and Sun must also be considered.

The length of the major axis of QuikSCAT's first elliptical orbit was $6,200 + 6,800 = 13,000$ kilometers.



In order to find other points on this ellipse, students must first determine the position of the second focus point. One way to do so is to note that the two focus points of an ellipse are symmetrical with respect to the point which bisects the major axis.

Since the first focal point of QuikSCAT's orbit (the center of the earth) is 300 kilometers to one side of the center point of the major axis, the second focal point will be on the major axis, 300 kilometers on the other side of the center point.

Once the two focal points are determined, students can determine other points on the ellipse by trial and error, finding points whose distances from the two focal points adds up to 13,000 kilometers.



The First QuikSCAT Orbit

When QuikSCAT was launched, its initial orbit was in the shape of an ellipse. (See footnote.)

You can think of an ellipse as a shape like a circle, but with two "center" points.

Circle

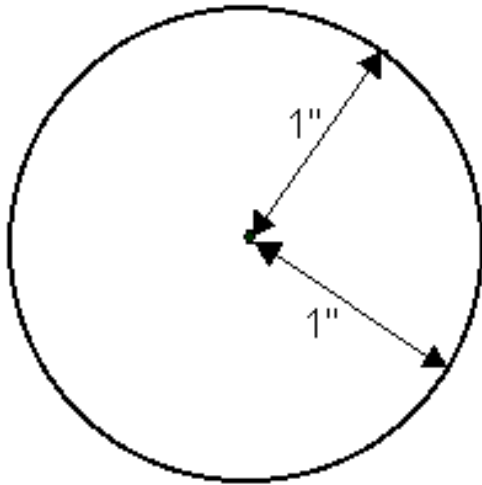

For every point on a circle, the distance to a certain point is the same. That certain point is called the "center".

Footnote: QuikSCAT was subsequently placed into a circular orbit, with an altitude of 803 kilometers.



Ellipse

For every point on an ellipse, the sum of the distances to two certain points is the same. Each of the two certain points is called a "focus" (the plural is "foci").

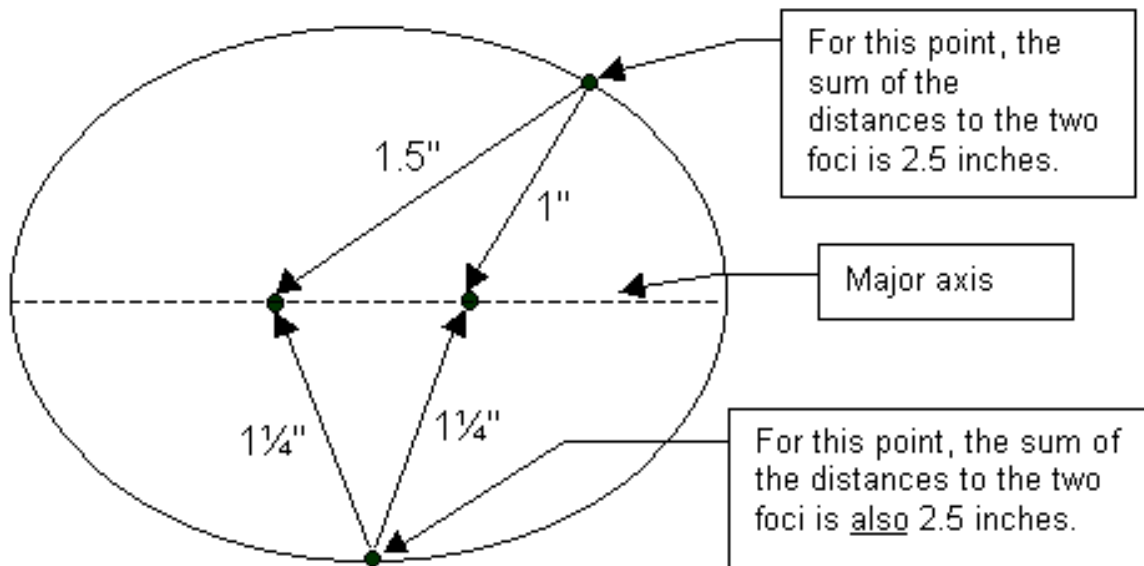

A line that stretches across the longest part of an ellipse is called its major axis (the dotted line, above).

Here's a fact you can use when you are working with ellipses: the length of the major axis is equal to the sum of the distances from any point on the ellipse to its two foci.

Measure the length of the major axis of the above ellipse and see if the above statement holds true for that ellipse.

Orbiting Satellites

Every satellite that is coasting along in orbit around the Earth travels along a path that is an ellipse, with the center of the Earth at one focus.



QuikSCAT's initial orbit was an ellipse which, at its closest point to the Earth, was about 200 kilometers above the Earth's surface. At its farthest point, it was about 800 kilometers above the Earth's surface.

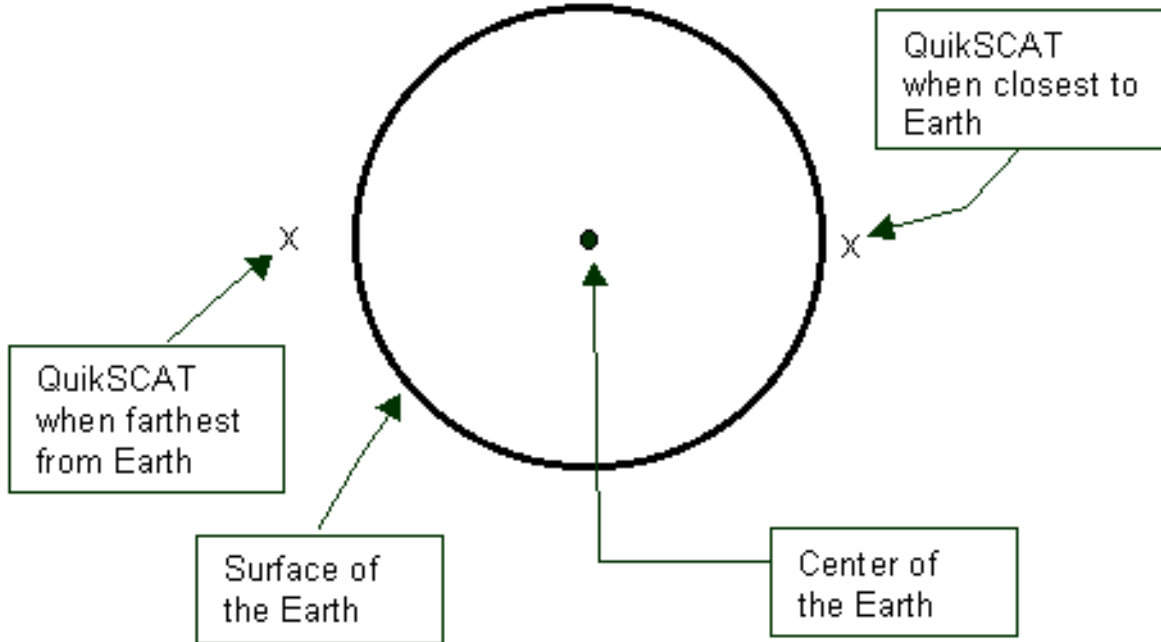

Since the Earth's radius is about 6000 kilometers, that means the QuikSCAT's orbit was 6200 kilometers from the center of the Earth at its closest, and 6800 kilometers from the center of the Earth at its farthest distance. This sketch shows these two positions (note that the radius of the Earth is 6000 kilometers).

Use a scale of 1000 kilometers = 1 centimeter, make a scale drawing which shows the earth and the two given positions of QuikSCAT.

3. Find the length of the major axis of this ellipse.
4. Using what you know about ellipses from the explanation above, show several other points on the initial QuikSCAT orbit in your drawing.
5. Sketch the orbit.

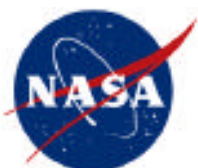

Teaching Guidelines for "QuikSCAT and the Law of Gravity"

Subject: Mathematics

Topics: Algebra: Equations

Grades: 6 - 9

Knowledge and Skills:

- Can do basic operations on both sides of an equation in such a way as to preserve the equality

Subject: Science

Topics: Physics (mass, motion, and force)

Grades: 6 - 12

Knowledge and Skills:

- Knows that the strength of the gravitational force between two masses is proportional to the masses and inversely proportional to the square of the distance between them

Materials: none

Answers

$v = \text{square root } (GM/r)$

For height of 800 km, $r = 6,800,000$ meters, and $v = 7.7$ km/sec.

For $v =$ half that value (3.85 km/sec), then $r = GM/v^2 = 27,000$ kilometers, which is 21,000 kilometers above the surface of the Earth.

Notes

Students will need to consider the fact that the distance between the center of the earth and the satellite is actually $6000 + 800 = 6800$ kilometers. To use the value of G given, distance must be measured in meters, and so $r = 6,800,000$ meters.

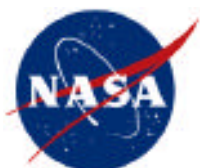

You may wish to discuss the implications of the fact that the mass of the satellite, "m", can be divided out of the equation. This means that the velocity of a satellite depends only on the height of its orbit above the earth, and not on its mass. This should remind students of Galileo's observation that all objects on earth fall at the same rate, regardless of their mass.

Galileo's observation can be understood as follows: objects with greater mass will be more strongly attracted to the earth (will be pulled with greater force), but will also have greater inertia (greater resistance to a change in motion). As the mass of an object increases, both of these effects increase in exactly the same way, and so the motion of the body stays the same.

For objects in orbit, similar reasoning applies: the effect of inertia is to cause the satellite to tend to fly away from the Earth in a straight line, not travel about it in a curved orbit. It is the force of gravity that keeps the satellite from doing so. Again, as mass increases the gravitational attraction increases in exactly the same way as the inertial effect, and so the actual motion of the satellite remains the same.

In practical terms, the effect of this is that there is a direct relationship between an object's speed and the height of its orbit: as the speed increases or decreases, so will its distance from the center of the earth. Thus an astronaut in a powered spacecraft can control the height of the craft's orbit by applying thrust in the direction of motion (increasing the speed, and rising) or applying thrust in the opposite direction (decreasing the speed, and falling). In this way a manned craft is able to "match orbits" with a space station.



QuikSCAT and the Law of Gravity

When an object is in circular orbit around the Earth, it is held in that orbit by the force of gravitational attraction between the object and the Earth. Because of this, the following equation holds true:

$$\frac{mv^2}{r} = \frac{GMm}{r^2}$$

In this equation, m is the mass of the object in orbit, M is the mass of the Earth, r is the distance between the center of the earth and the object, v is the velocity of the object, and G is a constant. If mass is measured in kilograms, velocity in meters per second and distance in meters, then G is equal to 6.7259×10^{-11} .

Solve the above equation for v .

The mass of the Earth is 5.976×10^{24} kg. If QuikSCAT is orbiting at a height of 800 kilometers above the surface of the Earth, what is its speed?

Suppose we wanted QuikSCAT to orbit at half that speed. How far above the Earth would its orbit be?

Can you use the above equation to find the mass of QuikSCAT, if you know its speed? Explain.



Teaching Guidelines for "Power Requirements"

Subject: Mathematics

Topics: Algebra: Equations

Grades: 6 - 9

Knowledge and Skills:

- Can do basic operations on both sides of an equation in such a way as to preserve the equality.

Subject: Science

Topics: Physics: Energy and Power; Applied Science and Technology: Electric Power Generation

Grades: 6 - 12

Knowledge and Skills:

- Understands the concept "power"
- Can apply the equation "energy = power x time"
- Understands various methods of solar energy collection

Materials: none

Procedure

It is essential that students understand the concepts of energy and power in order to do this activity.

For QuikSCAT, the average rate of energy delivery (power) for each square meter of panel is 18% of 40% of 1300 watts:

$$0.18 \times 0.40 \times 1300 = 93.6 \text{ watts.}$$



In a 24 hour period, the QuikSCAT solar panels are exposed to the sun for 12 hours. Thus the total amount of energy received by one square meter of panel in that period would be

$$\begin{aligned}\text{Total energy} &= \text{Power} \times \text{time} \\ &= 93.6 \text{ watts} \times 12 \text{ hours} \\ &= 1123 \text{ watt-hours.}\end{aligned}$$

If 20,000 watt-hours of energy is needed, and each square meter supplies 1123 watt-hours, then you would need $20,000/1123 = 17.8$ square meters of solar panels to supply the needed energy.

To supply 2.5 times as much energy (safety factor of 250%), you would need $2.5 \times 17.8 = 44.5$ square meters of solar panels. If the efficiency is reduced from 18% to 9%, then you would replace 0.18 by 0.09 in the equation above. Continuing the calculation as above, you would need 89 square meters of solar panels.

As a more intuitive approach to the last question, you may want to guide students to the realization that if the efficiency of the solar panels is cut in half, twice as much area will be needed to supply the same amount of energy.

As a related activity, ask students to bring in their home electricity bill and determine, from the total amount of kilowatt-hours used in a month, the average amount of power that is being used in their house. (Answer: Divide the total kilowatt-hours for the month by the number of hours in a month.)



Power Requirements

The total power requirement of the QuikSCAT instrument plus its spacecraft is about 20,000 watt-hours per day. The spacecraft's solar panels will need to produce at least this much energy each 24 hour period to keep the batteries charged.

When QuikSCAT is in orbit, the amount of sunlight power that arrives at the panels is 1300 watts per square meter of panel surface (when that surface is directly facing the sun). For two square meters of surface, the amount of sunlight power would be 2600 watts, etc.

However the panels do not directly face the sun at all times. The average amount of sunlight power absorbed will be about 40% of the maximum.

The panels will convert this light energy into electrical energy with an efficiency of 18%.

1. Keeping in mind that the panels are exposed to sunlight only half of the time while QuikSCAT is orbiting, how many watt-hours of electrical energy will be produced by one square meter of solar panel surface in a 24-hour period?
2. How many square meters of panel surface would be needed to supply the amount of energy needed by the satellite?
3. We want to design the panels so that that are capable of supplying 250% of QuikSCAT's energy needs, as a safety factor. How many square meters of panel would be required to accomplish this?
4. Less expensive solar panels are available which convert sunlight to electricity with an efficiency of 9%. How many square meters of such panels would be needed?

Background:

A watt is a unit of power, and is used to measure how fast energy is being delivered to or used by a piece of equipment. For example, a 100 watt light bulb uses energy twice as fast as a 50 watt light bulb.

A 100 watt light bulb which is left on for one hour will use a certain total amount of energy in that period. This amount of energy is described as 100 watt-hours. A one watt light bulb left on for 100 hours would also use 100 watt-hours of energy.



Teaching Guidelines for "Antenna Angle"

Subject: Mathematics

Topics: Trigonometry

Grades: 8 - 12

Knowledge and Skills:

- Can use sine, cosine and tangent ratios to solve for unknown sides of angles in right triangles

Ensure that students understand how changing the angle of the antenna changes the radius of the circular path of its beam. To do so you may wish to review that related image in the video.

Solving this problem requires the use of trigonometric ratios.

To find R, students can use either of these two equations:

$$\tan \theta = R/800$$

$$\cot \theta = 800/R$$

To find X, students may use either the Pythagorean Theorem (once they have found R) or either of these two equations:

$$\cos \theta = 800/X$$

$$\sec \theta = X/800$$

θ	R	X
5	70	803
10	141	812
15	214	828
20	291	851

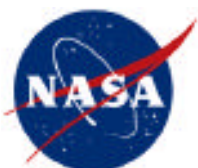

Antenna Angle

The QuikSCAT antenna is mounted at an angle, so that as it rotates it will sweep a circular pattern on the Earth (see diagram).

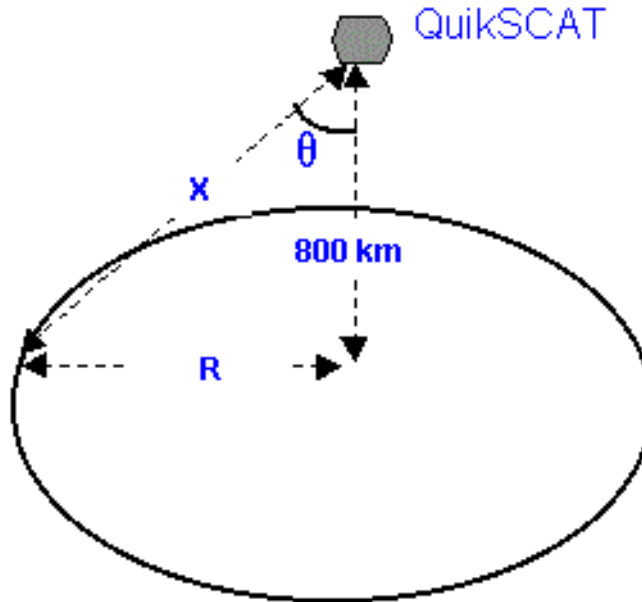

For each angle below, please determine:

The radius of the circular pattern that the radar beam would sweep (R)

The distance from the instrument to the point where the radar beam intersects the ocean surface (X)

	R	X
5		
10		
15		
20		

Suppose that we decide that we want R to be 900 kilometers. What should the mounting angle be? What would X be?



Teaching Guidelines for "An Alternative QuikSCAT Power Source"

Subject: Mathematics

Topics: Algebra: Exponential Functions

Grades: 10 - 12

Knowledge and Skills:

- Can determine the equation of an exponential function that closely matches a set of points

Procedure

Reading from the graph, in the worst case the power drops to 60% at roughly 12,000 hours. In the best case the power drops to 60% at roughly 20,000 hours.

To find the equation of the bottom (worst case) curve, select two points and substitute them into the general exponential equation $P = A \cdot \exp(Bt)$, where "P" is relative power and "t" is time. One obvious choice for a point to substitute is $P = 100$ at $t = 0$, which gives $A = 100$. For a second point, one might choose $t = 4$ and $P = 85$, giving the equation $85 = 100 \cdot \exp(4B)$. Solving this for B yields $B = .25 \cdot \ln(.85) = -.04063$. Thus the equation of this curve is $P = 100 \cdot \exp(-.04063 \cdot t)$.

Solving this for $P = 60\%$ gives $60 = 100 \cdot \exp(-.04063 \cdot t)$. Thus $t = \ln(0.6)/(-.04063) = 12.57$ thousands of hours.

The solution for the best case curve follows the same pattern.



An Alternative QuikSCAT Power Source

Solar panels are a proven means of supplying power for a satellite like QuikSCAT, but engineers should always consider possible alternatives. Another source of power which has been demonstrated to work well in other missions is the Radioisotope Thermoelectric Generator (RTG). RTG's have provided electrical power for some of the U.S. space program's greatest successes, including the Apollo lunar landings and the Viking landers that searched for life on Mars.

RTG's are lightweight, compact spacecraft power systems that are extraordinarily reliable. RTG's are not nuclear reactors and have no moving parts. They use neither fission nor fusion processes to produce energy. Instead, they provide power through the natural radioactive decay of plutonium (mostly Pu-238, a non-weapons-grade isotope). The heat generated by this natural process is changed into electricity by solid-state thermoelectric converters.

One characteristic of RTG's is that the amount of power that they generate decreases over time, as the plutonium decays. This decrease is an exponential function of time.

The curves below show two examples of this.

As an exercise, let's suppose that when the power produced by an RTG deteriorates to 60% of its maximum amount, QuikSCAT will no longer operate.

- Use the curves to estimate how long this would take in the best and worst cases.
- Use two points on each of the curves to determine its equation. Then use those equations to calculate how long QuikSCAT will operate in the best and worst cases.

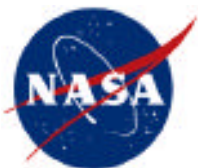

RTG Power Curve

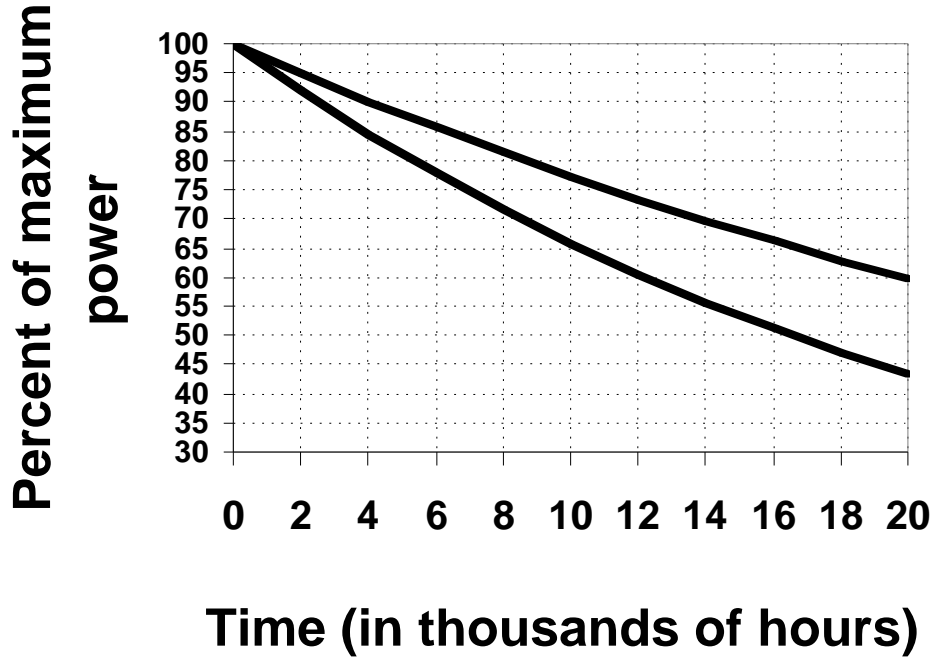

Glossary of Terms

Backscatter: Radar echoes from a target.

Coefficient of Thermal Expansion (CTE): The increment in volume of a unit volume of solid, liquid, or gas for a rise of temperature of 1° at constant pressure.

Electromagnetic: Pertaining to phenomena in which electricity and magnetism are related.

Electromagnetic radiation: Electromagnetic waves and, especially, the associated electromagnetic energy.

Electromagnetic Spectrum: The total range of wavelengths or frequencies of electromagnetic radiation, extending from the longest radio waves to the shortest known cosmic rays.

Ellipse: A closed plane curve generated by a point moving in such a way that the sums of its distances from two fixed points is constant.

Exponential function: The function $f(x) = e^x$, written $f(x) = \exp(x)$.

Hypotenuse: On a right triangle, the side opposite the right angle.

Microwave: A comparatively short electromagnetic wave which has a wavelength between about 0.3 and 30 centimeters.

Pythagorean Theorem: In a right triangle the square of the length of the hypotenuse equals the sum of the squares of the lengths of the other two sides.

Radar: A system using beamed and reflected radio-frequency energy for detecting and locating objects, measuring distance or altitude, and other purposes.

Radioisotope Thermoelectric Generator (RTG): A device for converting nuclear energy to electrical energy in which the heat produced by radioactivity of a radioisotope is used to produce a voltage in a thermocouple circuit.

Scatterometer: A microwave sensor that is essentially a radar without ranging circuits, used to measure only the reflection or scattering coefficient while scanning the surface of the earth from an aircraft or a satellite.



Sine function: The trigonometric function that for an acute angle is the ratio between the leg opposite the angle when it is considered part of a right triangle and the hypotenuse.

Solar Panel: An array of solar cells, connected in parallel and series that convert sunlight into electrical energy and are used as a power source.

